

The ZP785-3 is an addressable call point of stylish design, providing a manual means of initiating a fire alarm on ZP3 analogue addressable systems.

Complying with EN 54 Part 11, the ZP785-3 is suitable for installations meeting the recommendations of many local codes (e.g. BS 5839 Part 1).

The unit is operated either by pressing a resettable element (EN54 Part 11) or by breaking a frangible glass with finger pressure. Glass elements have clear vinyl coatings on the front surface to prevent operator injury and to inhibit the release of loose fragments as the glass is broken. Both operating elements are easily interchangeable.

Installed as part of the ZP3 analogue addressable system, up to 127 devices (call points, sensors and interface units) can be connected to each of the control panel loops. All loop devices incorporate switch settings enabling them to be assigned a unique address, which is polled by the panel every two seconds.

ZP785-3 callpoints are designed for semi recessed fixing, using a standard single gang socket box, or can be surface mounted by means of a Z-CPSB-1 matching plastic back box.

Push in terminals enable the device to be plugged directly into the loop, making replacement simple and reducing internal cable ends to a minimum.

System testing, glass replacement and reset are carried out by using a special maintenance tool enabling part of the front moulding including the glass, to be lowered, allowing the device to operate.

Rated at IP24 the ZP785-3 moulding is constructed of ABS plastic and intended for indoor applications. A red LED indicator is prominently positioned on the front of the unit, which illuminates when the device is operated.

For locations where malicious operation, or accidental impact from flying objects may occur (for example sports halls), operation can be restricted by the addition of a clear, polycarbonate, front cover (Z-MCP-HC), which can be further protected by a cover seal (Z-MCP-HCS). In use the seal must be broken, prior to raising the front cover.



ZP785-3

Addressable Callpoint

- **Modern stylish design**
- **Complies with EN54 Part 11**
- **Resettable or frangible operating elements**
- **Single maintenance tool**
- **Plug in loop connection**

Dimensions

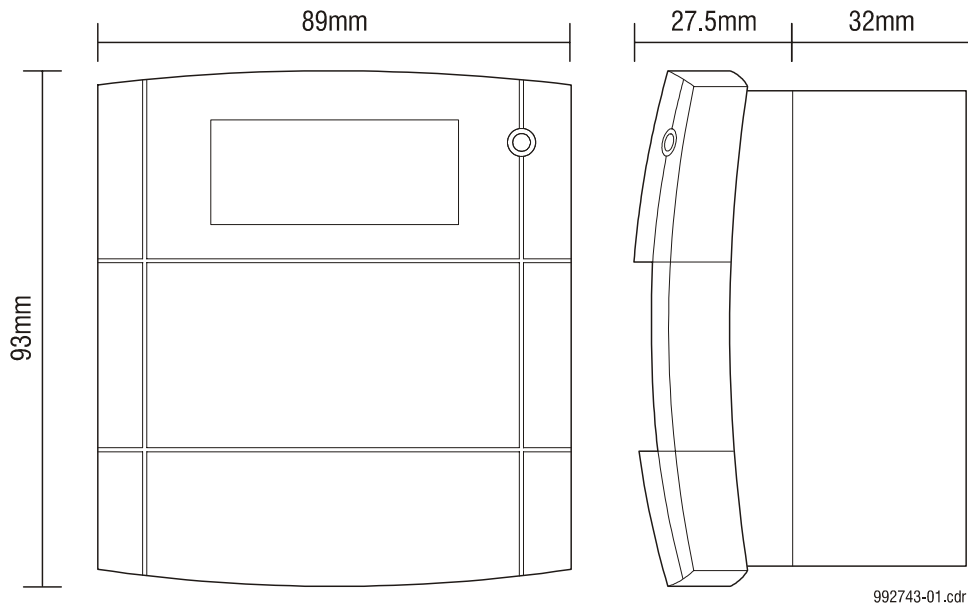

Wiring Schematic

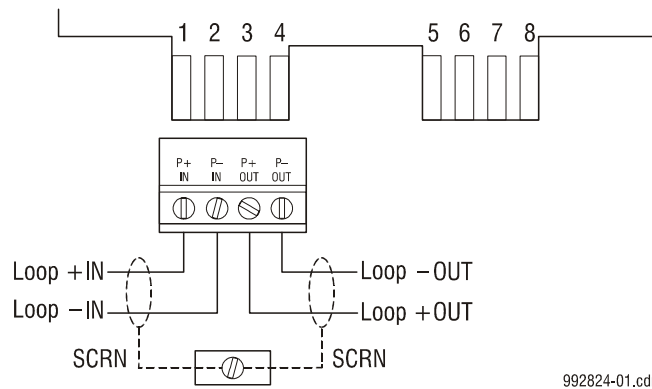

Specification



Model No.	ZP785-3
Specification	EN54 Pt11
Description	Addressable callpoint
Performance	EN54 Part 11
Compatibility	All ZP analogue addressable systems
Mounting	Addition of Z-CPSB-1 back box for surface or single gang socket box for semi flush fixing
Wiring	ZP loop – 2 core plus screen, continuity must be maintained.
Monitoring:	Open and short circuit loop wiring faults
Indication	Alarm LED (red)
Operating voltage	16 – 22 Vdc
Current (quiescent)	600µA
Current (alarm)	700µA

Operating principle	Micro switch
Environmental:	
Application	Indoor use
EN60529 rating	IP24
Temp range	-30°C to +70°C
Humidity range	0% to 95% RH (non condensing)
EMC	CE marked (EEC89/336)
Construction:	
Material	Moulded ABS
Dimensions	93mm (H) x 89mm (W) x 27.5mm (D) – recessed 59.5mm (D) - with surface back box
Colour	Red
Weight	125g

Ziton
 8 Newmarket Court Chippenham Drive Kingston Milton Keynes MK 10 0AQ United Kingdom
 Telephone +44 (0) 1908 281981 Fax +44 (0) 1908 282554 email zitonuk@ziton.spx.com

Ziton (Pty) Ltd
 Ziton House 555 Voortrekker Road Maitland 7405 PO Box 181 Maitland 7404 South Africa
 Telephone +27 (0)21 506 6000 Fax +27 (0)21 506 6100 email zitonza@ziton.spx.com

Copyright © Ziton
 Ziton reserves the right to change specifications without notice in order to improve products or manufacturing methods. Although every effort is made to avoid errors, we reserve the right to correct typographical, photographic, clerical or printing errors.