

Electromagnetic DOOR HOLDERS
Reinforced aluminium housing - with release button
Surface mounting - IP 52

SERIES **M 9200 D**
M 9400 D



STANDARD FEATURE

Electromagnetic door holder for fire proof doors, mounted in a reinforced aluminium housing, has a spring loaded device to eliminate the residual magnetism, including the diode of protection, release button and electrical terminal connection.

Series M 9200 and M 9400 electromagnetic door holders are specially designed for use in areas of vandalism (school, colleges, public area...) or industrial area (warehouse, exhibition centre, supermarket, hospital...), or can be suited for every type of fire system protection.

Product individually packed with fitting instructions and white galvanised steel amortized flat keeper plate.

TECHNICAL SPECIFICATIONS

Holding force

SERIES M 9200 D 20 daN
SERIES M 9400 D 40 daN

Voltage

Available versions : 24 Vdc or 48 Vdc
Only for SERIES M 9200 115 or 240 Vac

Nominal power at 20°C

SERIES M 9200 D 0,6 watt
SERIES M 9400 D 1,6 watt

Electrical protection class

III for 24 or 48 Vdc / I for 115 or 240 Vac
ATTENTION! 115 or 240 Vac units are insulation class I and the earth lead must be wired between the earth connector and the earth terminal on the metal mounting box.

Protection rating

IP 52 - EN 60529

Electrical connection

Terminal board

Box colour

Grey RAL 9002 painted steel

Door holders are generally linked to a fire system that will automatically release the doors in case of fire by switching the power off. If required, it can be also manually operated by the release button.

IN CONFORMITY WITH THE :
EN 1155
BS 5839 part 3

TECHNICAL DIMENSIONS

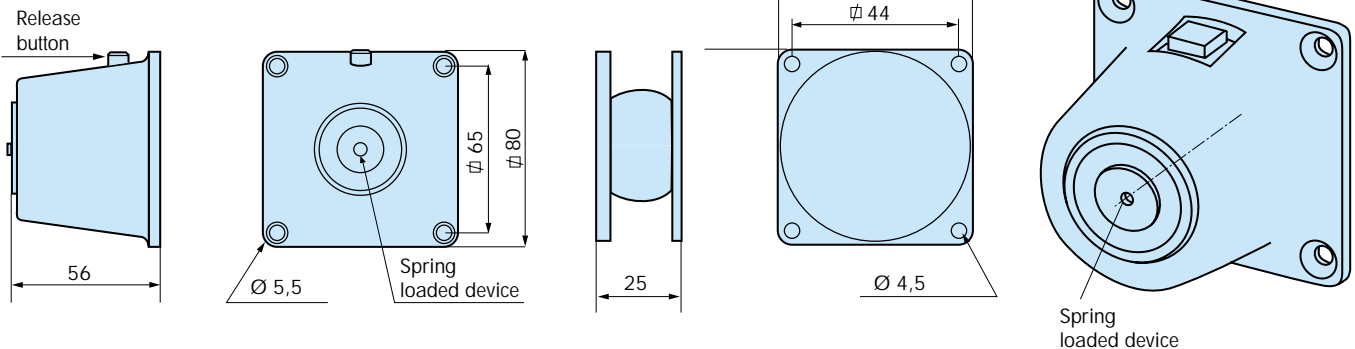

ACCESSORIES FOR SERIES M 9200D - M 9400 D



Series M 9200-M 9400
with
AC 916.20.06 - 45 mm



Series M 9200 - M 9400
with
AC 916.20.31- 150 mm



Series M 9200 - M 940D
with
AC 916.20.32 - 250 mm



Electromagnetic DOOR HOLDERS
Reinforced aluminium housing - with release button
Surface mounting - IP 52

SERIES **M 9200 D**
M 9400 D

ITEMS	Holding force	Voltage	Release button	DIODE	Keeper plate
-------	---------------	---------	----------------	-------	--------------

SERIES M 9200 D

M 9212 D	20 daN	24 Vdc	YES	YES	FLAT
M 9222 D	20 daN	48 Vdc	YES	YES	FLAT

SERIES M 9400 D

M 9412 D	40 daN	24 Vdc	YES	YES	FLAT
M 9422 D	40 daN	48 Vdc	YES	YES	FLAT

Comsec Protection Systems Ltd., Unit 26, Stadium Business Park, Ballycoolin Road, Dublin 11
PHONE: (01) 8853008 - FAX: +353 (01) 8853007 EMAIL: info@comsec.ie - WEB:
http://www.comsec.ie

MOUNTING EXEMPLE

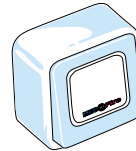
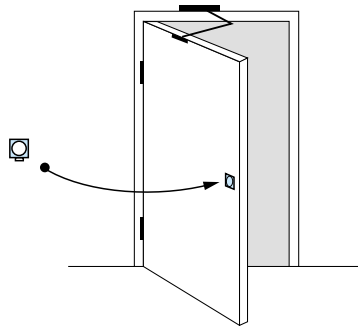

Please note:

It must be possible to release a fire protection door held open by an electromagnet with a hand switch which is not hidden by the door. (not included)

