

A105N / A112N Appello Speech & Tone Voice Annunciation unit



comsec
protection systems

- Maximum output: A105N: 105dB(A) @ 1 metre
A112N: 110dB(A) @ 1 metre
- Direct message storage on silicon: 16 seconds of speech
- Very high voice reproduction quality (moving coil loudspeaker)
- 10 alarm tones (including silence to allow speech only option) UKOOA/ PFEER compliant.
- Volume control & tone duration control.
- Message length: 1 x 16 seconds or 2 x 8 seconds.
- Voltages: 12vdc(9-15vdc); 24vdc(18-30vdc); 115vac; 230vac.
- Easy message creation with built in microphone.
- Edits automatically to message length.
- DC versions have reverse polarity diode protection.
- IP55 - can be increased to IP66 (dust protected, watertight) with WR kit.
- Tropicalisation available on request.
- Enclosure material: UL94V0 & 5VA rated FR ABS
- Colour available: Red (RAL3000), Grey or White.
- Operating temperature: -25 to +55°C
- Storage temperature: -40 to +70°C
- Relative humidity: 90% at 20°C
- Weight: A105N DC: 0.75Kg AC: 1.00Kg
A112N DC: 1.80Kg AC: 2.10Kg



The sounder records, stores and plays back user defined messages stored directly to non-volatile memory without any intermediate analogue to digital conversion.

A single 16 second, or two 8 second messages may be recorded and played back with a choice of 1 of 10 user selectable alarm tones.

- Cable gland knockouts in the rear of the unit.
- Side M20 cable gland entry and IP55 stopping plug.
- Unit can be mounted using external lugs or internal BESA compatible fixing positions.
- All units offer IN and OUT terminals
- Terminals accept 0.5 to 2.5mm² cables.

Input voltages and current consumption.

Voltage :	12vdc	24vdc	115vac	230vac
			50/60Hz	50/60Hz
Voltage range :	9-15vdc	18-30vdc	+/-10%	+/-10%
Current mA :	150mA	180mA	40mA	20mA

A105N Appello DC Dimensions.

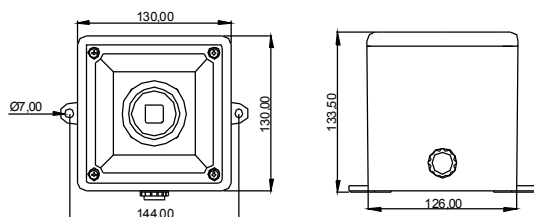

A105N Appello AC Dimensions.

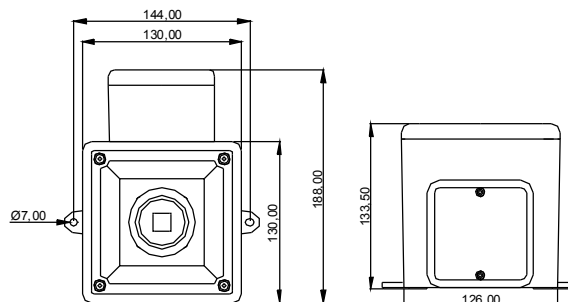



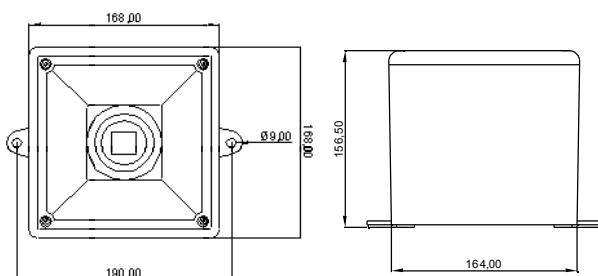

A112N Dimensions.

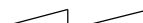
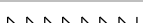

Other products in the Appello range include a Synchronised version of the Speech & Tone sounder (10 alarm tones), and also a P.I.R. activated version.

The Appello technology is also available in an ATEX approved explosionproof housing as the BExA110 & BExA120 units.

All dimensions are in millimetres.

Stage 1	Frequency Description	dB @ 1m	Cycles
Tone 1	800/1000Hz @ 0.25 sec Alternating	106dB(A) @ 1m	 4 cycles
Tone 2	500/1200Hz @ 0.3Hz 0.5 sec Slow Whoop	106dB(A) @ 1m	 2 cycles
Tone 3	1200/500Hz @ 1Hz - DIN / PFEER P.T.A.P.	106dB(A) @ 1m	 4 cycles
Tone 4	544Hz (100mS)/440Hz (400mS) - NF S 32-001	104dB(A) @ 1m	 4 cycles
Tone 5	1000Hz Continuous - PFEER Toxic Gas	106dB(A) @ 1m	————— 2 cycles
Tone 6	Bell	100dB(A) @ 1m	 2 cycles
Tone 7	1KHz 1s on, 1s off Intermittent - PFEER Gen. Alarm	106dB(A) @ 1m	- - - - - 3 cycles
Tone 8	420Hz @ 0.625 sec Australian Alert	103dB(A) @ 1m	- - - - - 4 cycles
Tone 9	500-1200Hz 3.75sec /0.25sec. Australian Evac.	106dB(A) @ 1m	 2 cycles
Tone 10	No tone - 0.5 second gap		

Note: SPL readings are at nominal voltage, typically +/-3dB and are for indication purposes only. Where applicable, reduce outputs by 5dB when a 10-30vdc unit is supplied 12vdc. SPL readings are for the A105N Appello unit only.

DC unit wiring configuration.

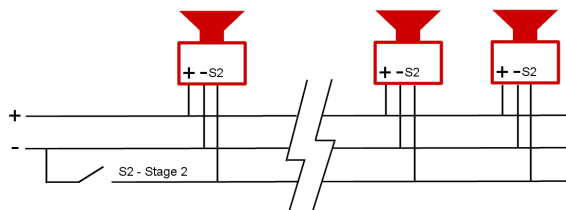

AC unit wiring configuration.

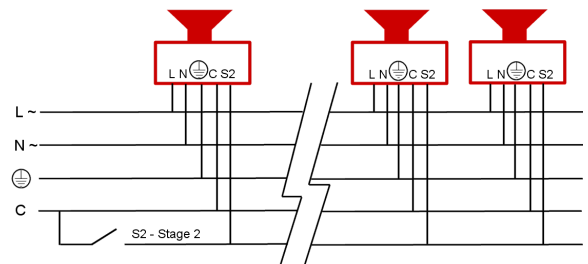

Ordering code :

A105NAPPT

DC

24

R

Product
A105NAPPT
A112NAPPT

Supply
DC
AC

Voltage
12
24
48
115
230

Housing
R Red
W White
G Grey



Also available:

- **A100** AlertAlarm - 32 tones 104dB(A).
- **A105N** AlertAlarm - 32 tones 112dB(A).
- **A112** AlertAlarm - 45 tones 119dB(A).
- **A121** AlertAlarm - 45 tones 126dB(A).