

# BExCBG05-05D ATEX EEx Hazardous Area Dual Xenon Beacons

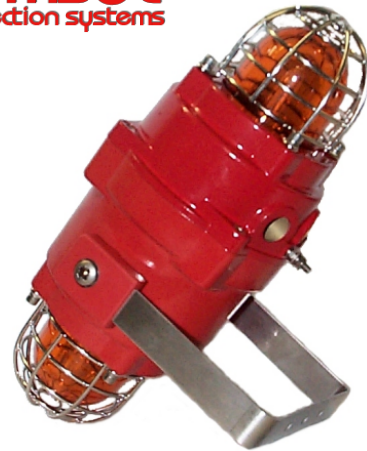

**BExCBG05-05D**  
Flameproof & Dust ignition proof beacons  
Zones 1, 2, 21 & 22  
Ⓢ II 2G/D EEx d IIC T5 T100°C

- Dual 5 Joule Xenon : 1Hz (60 FPM) (5 Ws).
- BExCBG05-05D : EEx d IIB T5 (Tamb. -50 to +55°C)
- ATEX / CENELEC / FTZU
- Suitable for Zone 1, 2, 21 & 22, Gas Groups IIB & IIA
- Voltages : 12vdc; 24vdc; 48vdc; 115vac; 230vac
- Six lens colours available : Amber, Blue, Clear, Green, Red & Yellow
- Automatic synchronisation on multi-beacon systems
- Beacons can be set to 'flip-flop' alternating mode with other units on multi-beacon systems.
- Tube life : emissions reduced to 70% after 8 million flashes
- Xenon tubes mechanically secured against shock/vibration
- BExCBG05-05D : IP67
- Enclosure material : Marine grade LM6 Aluminium
- Chromated & powder coated finish - good resistance to humidity and salt spray environments.
- Glass lens & Stainless Steel guard.
- Colour available : Red (RAL3000)
- Operating temperature : -50 to +55°C
- Storage temperature : -50 to +70°C
- Large range of certified end of line resistors.
- Weight : DC:4.00kg AC: 4.35kg
- KEMA Certificate number : 01ATEX2222

**Installation Features.**

- Very large termination area.
- Dual M20 ISO cable gland entries (supplied with one stopping plug).
- Ratchet adjustable stainless steel 'U' bracket for positive adjustment under harsh conditions.
- IN & OUT terminals
- Terminals accept 0.5 to 4.0mm<sup>2</sup> cables.
- Line monitoring : Min. 500 Ohm 2w, or 3k3 Ohm 0.5w resistor, or diode within EExd enclosure (dc versions)

The beacons may be connected from a single supply for simultaneous operation or from separate supplies for independent operation.

Input voltages and current consumption for each BExCBG05-05D Beacon component.

Voltage :	12vdc	24vdc	48vdc	115vac 50/60Hz	230vac 50/60Hz
Voltage range :	10-14v	20-28v	42-54v	+/-10%	+/-10%
Current mA :	750mA	270mA	180mA	140mA	55mA

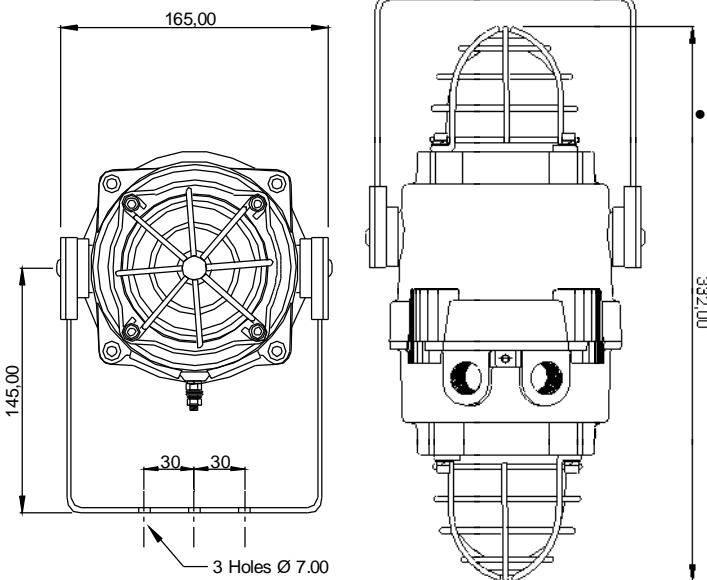

All dimensions are in millimetres.

**Also available :**

- BEx(D)S110 & 120 EEx d & EEx de sounder units.
- Programmable versions with 45 tones and 4 stages.
- BEx(D)A110 & A120 EEx d & EEx de Voice Annunciation units.
- BExBG EEx d & EEx de 10 & 15 Joule Xenon beacons
- BEx(D)L15 & 25 watt EEx d & EEx de loudspeakers.
- BEx(D)TS110 & BExTBG05 EEx d Telephone ringers and beacons.

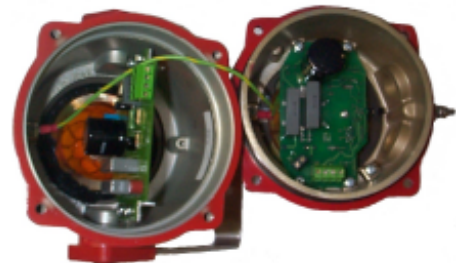

Synchronised mode.

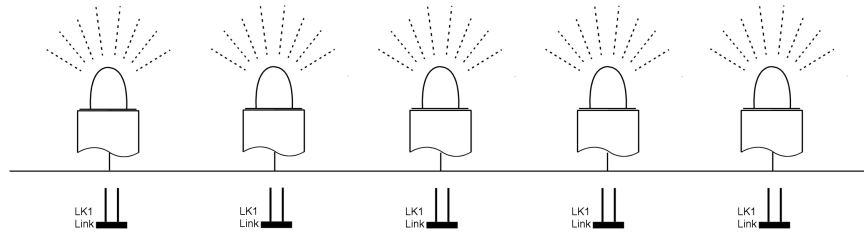

Flip-Flop (alternating) mode.

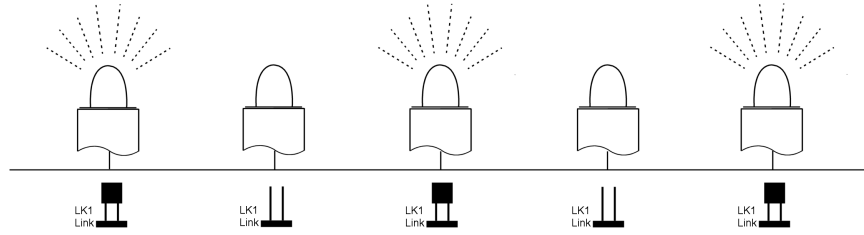

Ordering code : BExCBG05-05D    24    DC    -    A    /    R

Product	Voltage	Supply	Lens		Lens	
BExCBG05-05D	12	DC	A	Amber	A	Amber
	24	AC	B	Blue	B	Blue
	48		C	Clear	C	Clear
	115		G	Green	G	Green
	230		R	Red	R	Red
			Y	Yellow	Y	Yellow

N.B IMPORTANT NOTICE : THE BExCS110-05D, BExCA110-05D, BExCL15-05D, BExCBG05-05D ARE NOT FOR SALE, RE-SALE, INSTALLATION, OR USE WITHIN THE UNITED STATES OF AMERICA AS A SOLE, MULTIPLE, INTEGRATED, OR INCORPORATED UNIT.