

E2xS112 Alarm Horn Sounder Zone 2 & Division 2



- Nominal output : 110dB(A) @ 1m +/-3dB
 - 45 alarm tones (UKOOA/PFEER compliant)
 - 3 stage alarm , remotely selectable.
 - Volume control
 - Automatic synchronisation on multi-sounder systems
 - 100m effective range @ 1kHz
 - Voltages : 24vdc(10-30vdc); 48vdc(38-58vdc); 120vac; 230vac
 - Enclosure material : UL94V0 PPS & ABS
 - Weight : DC: 2.50Kg AC: 3.00Kg
 - ATEX: IP66 & IP67
 - UL: Type 4, 4X & 13
-
- ATEX: E2xS112EG
Zone 2 Ex II 3G EEx nA nL IIC T4 (Tamb -20°C to +55°C)
Cert: DEMKO 06 ATEX 0421554
 - UL: E2xS112UL
Class I, Division 2, Groups A,B,C,D T3C (160°C) (at +55°C)
Class I, Division 2, Groups A,B,C,D T4 (135°C) (at +40°C)
Class II, Division 2, Groups F & G T6 (85°C)
Class III, Division 1, T6 (85°C)
File: E230764
-
- Large termination area
 - ATEX: 2 x M20 ISO cable gland entries (with 1 blanking plug).
 - UL: 1 x 1/2"NPT cable gland entry with flying leads (0.5m)
 - Ratchet adjustable stainless steel 'U' bracket for 360° positioning.
 - ATEX 'EG' units offer IN & OUT terminals
 - ATEX 'EG' unit terminals accept 0.5 to 2.5mm²cables.



High output alarm sounder for hazardous environments with high ambient noise levels.

Input voltages and current consumption for the E2x112 sounder.

Voltage :	24vdc	48vdc	120vac	230vac
			50/60Hz	50/60Hz
Voltage range :	10-30vdc	38-58vdc	+/- 10%	+/- 10%
Current mA :	284mA	146mA	104mA	54mA

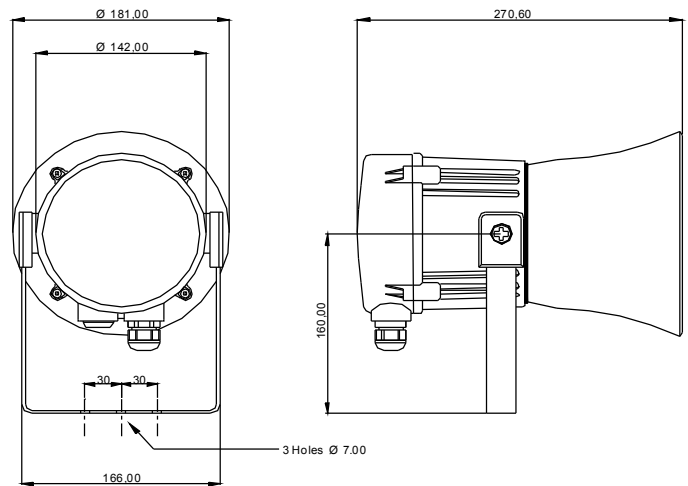

All dimensions are in millimetres.

Also available :

- E2xCS112-05 Combined alarm sounder & xenon beacon
- E2xL15 15w PA loudspeaker
- E2x121 High output alarm sounders
- E2xB05 & E2xB10 5 and 10 Joule xenon beacons



Stage 1	Frequency Description	dB @ 1m	Stage 2	Stage 3
Tone 1	340 Hz Continuous	107dB(A) @ 1m	Tone 2	Tone 5
Tone 2	800/1000Hz @ 0.25 sec Alternating	112dB(A) @ 1m	Tone 17	Tone 5
Tone 3	500/1200Hz @ 0.3Hz 0.5 sec Slow Whoop	113dB(A) @ 1m	Tone 2	Tone 5
Tone 4	800/1000Hz @ 1Hz Sw eeping	113dB(A) @ 1m	Tone 6	Tone 5
Tone 5	2400Hz Continuous	119dB(A) @ 1m	Tone 3	Tone 20
Tone 6	2400/2900Hz @ 7Hz Sw eeping	116dB(A) @ 1m	Tone 7	Tone 5
Tone 7	2400/2900Hz @ 1Hz Sw eeping	116dB(A) @ 1m	Tone 10	Tone 5
Tone 8	500/1200/500Hz @ 0.3Hz Sw eeping	113dB(A) @ 1m	Tone 2	Tone 5
Tone 9	1200/500Hz @ 1Hz - DIN / PFEER P.T.A.P.	113dB(A) @ 1m	Tone 15	Tone 2
Tone 10	2400/2900Hz @ 2Hz Alternating	119dB(A) @ 1m	Tone 7	Tone 5
Tone 11	1000Hz @ 1Hz Intermittent	112dB(A) @ 1m	Tone 2	Tone 5
Tone 12	800/1000Hz @ 0.875Hz Alternating	112dB(A) @ 1m	Tone 4	Tone 5
Tone 13	2400Hz @ 1Hz Intermittent	119dB(A) @ 1m	Tone 15	Tone 5
Tone 14	800Hz 0.25sec on, 1 sec off Intermittent	113dB(A) @ 1m	Tone 4	Tone 5
Tone 15	800Hz Continuous	113dB(A) @ 1m	Tone 2	Tone 5
Tone 16	660Hz 150mS on, 150mS off Intermittent	109dB(A) @ 1m	Tone 18	Tone 5
Tone 17	544Hz (100mS)/440Hz (400mS) - NF S 32-001	109dB(A) @ 1m	Tone 2	Tone 27
Tone 18	660Hz 1.8sec on, 1.8sec off Intermittent	109dB(A) @ 1m	Tone 2	Tone 5
Tone 19	1.4KHz-1.6KHz 1s, 1.6KHz-1.4KHz 0.5s -NFC48-265	114dB(A) @ 1m	Tone 2	Tone 5
Tone 20	660Hz Continuous	109dB(A) @ 1m	Tone 2	Tone 5
Tone 21	554Hz/440Hz @ 1Hz Alternating	109dB(A) @ 1m	Tone 2	Tone 5
Tone 22	544Hz @ 0.875 sec. Intermittent	109dB(A) @ 1m	Tone 2	Tone 5
Tone 23	800Hz @ 2Hz Intermittent	113dB(A) @ 1m	Tone 6	Tone 5
Tone 24	800/1000Hz @ 50Hz Sw eeping	112dB(A) @ 1m	Tone 29	Tone 5
Tone 25	2400/2900Hz @ 50Hz Sw eeping	116dB(A) @ 1m	Tone 29	Tone 5
Tone 26	Bell	108dB(A) @ 1m	Tone 2	Tone 15
Tone 27	554Hz Continuous	109dB(A) @ 1m	Tone 26	Tone 5
Tone 28	440Hz Continuous	106dB(A) @ 1m	Tone 2	Tone 5
Tone 29	800/1000Hz @ 7Hz Sw eeping	112dB(A) @ 1m	Tone 7	Tone 5
Tone 30	300Hz Continuous	107dB(A) @ 1m	Tone 2	Tone 5
Tone 31	660/1200Hz @ 1Hz Sw eeping	112dB(A) @ 1m	Tone 26	Tone 5
Tone 32	Tw o tone chime.	108dB(A) @ 1m	Tone 26	Tone 15
Tone 33	745Hz @ 1Hz Intermittent	109dB(A) @ 1m	Tone 2	Tone 5
Tone 34	1000 & 2000Hz @ 0.5 sec Alternating - Singapore	114dB(A) @ 1m	Tone 38	Tone 45
Tone 35	420Hz @ 0.625 sec Australian Alert	108dB(A) @ 1m	Tone 36	Tone 5
Tone 36	500-1200Hz 3.75sec /0.25sec. Australian Evac.	113dB(A) @ 1m	Tone 35	Tone 5
Tone 37	1000Hz Continuous - PFEER Toxic Gas	112dB(A) @ 1m	Tone 9	Tone 45
Tone 38	2000Hz Continuous	116dB(A) @ 1m	Tone 34	Tone 45
Tone 39	800Hz 0.25sec on, 1 sec off Intermittent	113dB(A) @ 1m	Tone 23	Tone 17
Tone 40	544Hz (100mS)/440Hz (400mS) - NF S 32-001	112dB(A) @ 1m	Tone 31	Tone 27
Tone 41	Motor Siren - slow rise to 1200 Hz	113dB(A) @ 1m	Tone 2	Tone 5
Tone 42	Motor Siren - slow rise to 800 Hz	114dB(A) @ 1m	Tone 2	Tone 5
Tone 43	1200 Hz Continuous	113dB(A) @ 1m	Tone 2	Tone 5
Tone 44	Motor Siren - slow rise to 2400 Hz	118dB(A) @ 1m	Tone 2	Tone 5
Tone 45	1KHz 1s on, 1s off Intermittent - PFEER Gen. Alarm	112dB(A) @ 1m	Tone 38	Tone 34

Note: SPL readings are at nominal voltage, typically +/-3dB and are for indication purposes only. Where applicable, reduce outputs by 5dB when a 10-30vdc unit is supplied 12vdc.

DC unit wiring configuration.

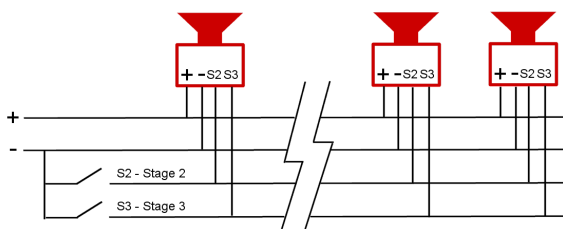

AC unit wiring configuration.

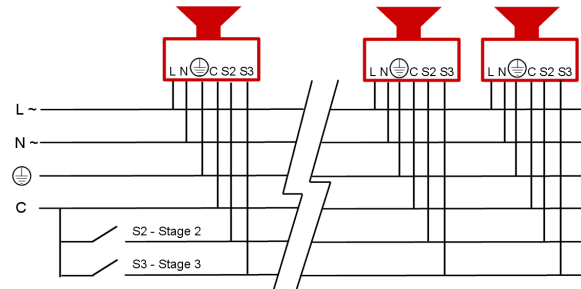

Ordering code :

E2xS112	UL	24DC
Product	Type	Voltage
E2xS112	EG	24DC
	UL	48DC
		115AC
		230AC