

# MCL15-05 Marine Grade IP67 15w Loudspeaker & Xenon Beacon



**comsec**  
protection systems



## Loudspeaker.

- SPL : 108dB +/-3dB @ 1w @ 1m - Pink noise  
118dB +/-3dB @ 15w (Rated Power) @ 1m
- Rated power : 15 Watts RMS
- 70v line transformer version : 15w / 7.5w / 3w / 1w tapings  
(z=336.67 Ohms / 653.33 Ohms / 1.6kOhms / 4.9kOhms)
- 100v line transformer version : 15w / 7.5w / 3w / 1w tapings  
(z=666.87 Ohms / 1.34kOhms / 3.34kOhms / 10kOhms)
- Impedance type : 8 Ohm or 16 Ohm
- Dispersion : 120° @ 1kHz & 32° @ 4kHz
- Frequency range : 400Hz to 8000Hz
- DC line monitoring :  
2.2uF Capacitor Transformer type speaker  
470uF Capacitor Impedance type speaker
- Transformer type fitted with thermal fuse
- Complies with BS5839 part 8

## Beacon.

- Beacon: 5 Joule @ 1Hz (5 Ws).
- Automatic synchronised flash, or Flip-Flop alternating mode.
- 6 lens colours available.
- Beacon voltage: 12vdc; 24vdc; 48vdc; 115vac; 230vac
- DC versions have reverse polarity protection.
- Xenon tube mechanically secured against vibration/shock.

- Third party tested to IP67 & IP66
- Enclosure material : UL94V0 & 5VA rated FR ABS
- Colour available : Grey (RAL7038)
- Operating temperature : -25 to +55°C
- Storage temperature : -40 to +70°C
- Relative humidity : 90% at 20°C
- Weight : 70/100v line : 2.60kg  
Low impedance : 2.20kg

A heavy duty high output IP67 sealed loudspeaker & beacon, ideal for harsh environments with high ambient noise levels also requiring a visual indicator.

- Large termination area
- 2 x M20 ISO cable gland entries (with 1 blanking plug).
- Ratchet adjustable stainless steel 'U' bracket for 360° positioning.
- All units offer IN & OUT terminals
- Terminals accept 0.5 to 4.0mm<sup>2</sup> cables.

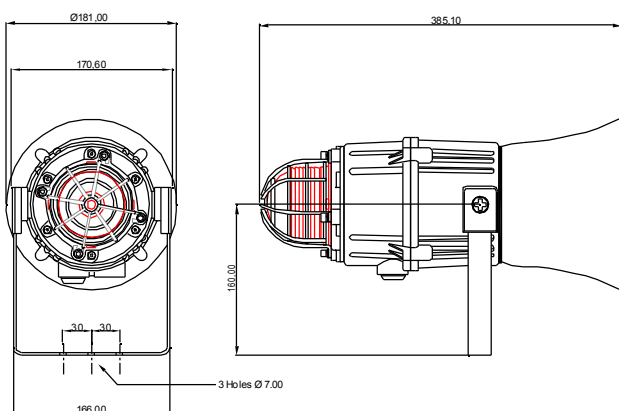
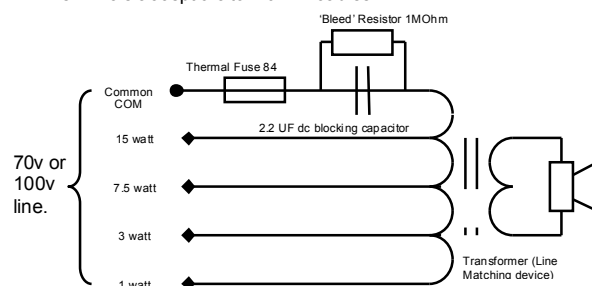

All dimensions are in millimetres.

## MCL15-05 8 & 16 Ohm low impedance:

Input : 8 Ohm    Power : 15Watts    I/P Volts : 10.95V  
Input : 16 Ohm    Power : 15Watts    I/P Volts : 15.49V

Input voltages and current consumption for the MCL15-05 beacon component.

Voltage :	12vdc	24vdc	48vdc	115vac	230vac
				50/60Hz	50/60Hz
Voltage range :	10-14v	20-28v	42-54v	+/-10%	+/-10%
Current mA :	550mA	300mA	180mA	140mA	55mA

Also available :

- MCA112-05** combined sounder & beacon
- ML15** 15w & **ML25** 25w marine loudspeaker
- MA112** & **MA121** high output marine sounders
- MB005** & **MB010** 5 and 10 Joule marine beacons
- MV112** high output marine voice annunciation unit



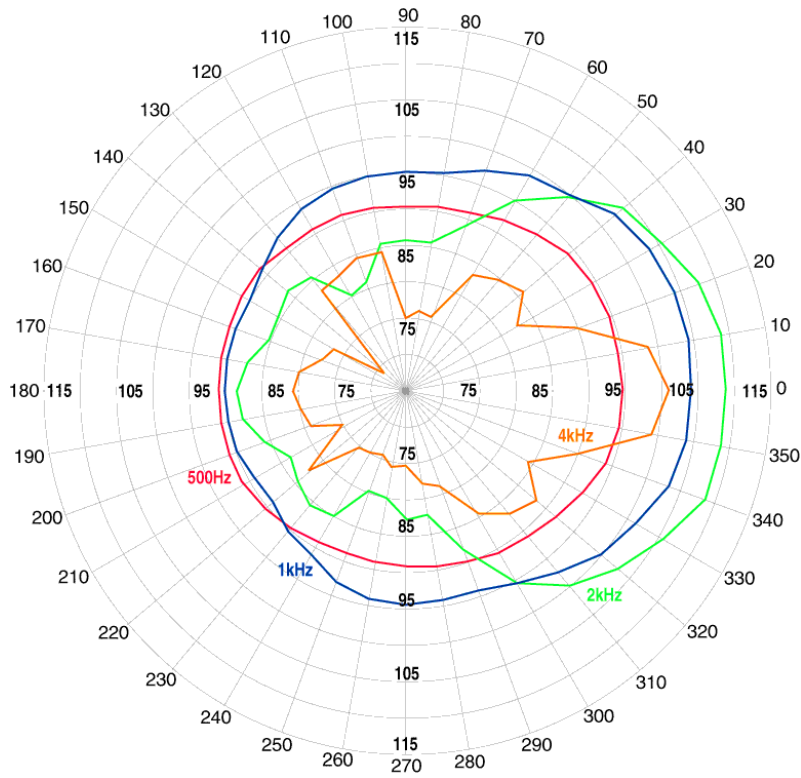
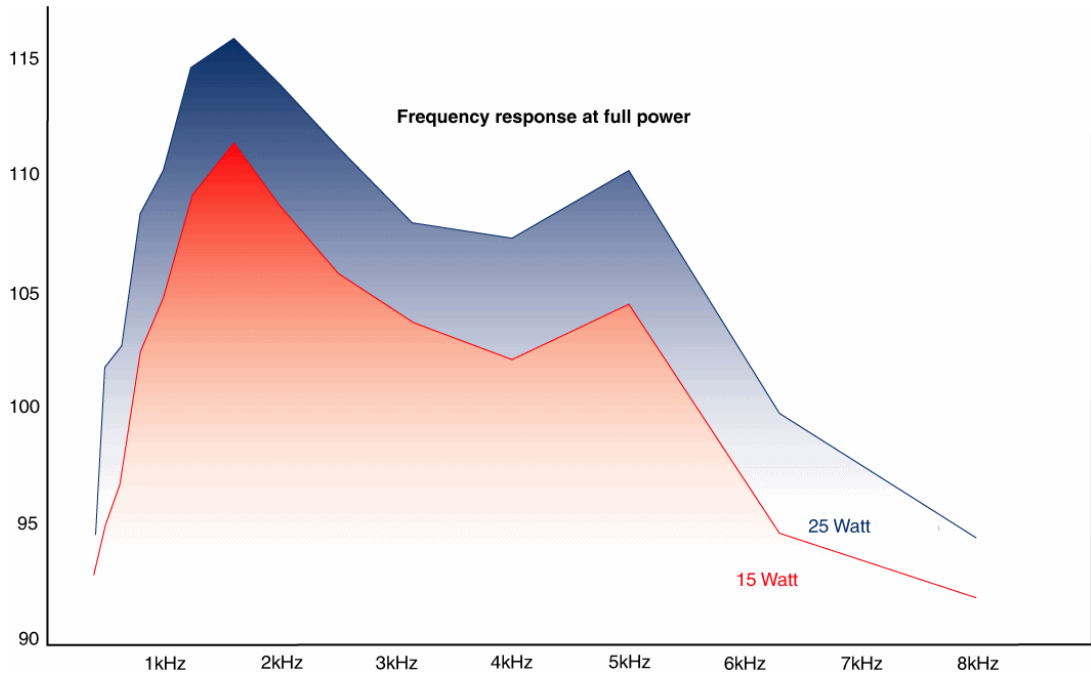

Ordering code :

<u>MCL15-05</u>	<u>100V</u>	<u>DC</u>	<u>24</u>	<u>G</u>	<u>/</u>	<u>A</u>
Product MCL15-05	Version 70V Line 100V Line 8 Ohm 16 Ohm	Supply DC AC	Voltage 12 24 48 115 230	Housing G Grey		Lens A Amber B Blue C Clear G Green R Red Y Yellow

TSP3608-B

No liability is accepted for any consequence of the use of this document. The technical specification of this unit is subject to change without notice due to our policy of continual product development. All dimensions are approximate. This unit is sold subject to our standard conditions of sale, a copy of which is available on request.

Comsec Protection Systems Ltd., Unit 26, Stadium Business Park, Ballycoolin Road, Dublin 11  
 PHONE: (01) 8853008 - FAX: +353 (01) 8853007  
 EMAIL: info@comsec.ie - WEB: http://www.comsec.ie