

ML15 Marine Grade IP67 15 Watt Loudspeaker



- SPL : 108dB +/-3dB @ 1w @ 1m - Pink noise
118dB +/-3dB @ 15w (Rated Power) @ 1m
- Rated power : 15 Watts RMS
- 70v line transformer version : 15w / 7.5w / 3w / 1w tapings
(z=336.67 Ohms / 653.33 Ohms / 1.6kOhms / 4.9kOhms)
- 100v line transformer version : 15w / 7.5w / 3w / 1w tapings
(z=666.87 Ohms / 1.34kOhms / 3.34kOhms / 10kOhms)
- Impedance type : 8 Ohm or 16 Ohm
- Dispersion : 120° @ 1kHz & 32° @ 4kHz
- Frequency range : 400Hz to 8000Hz
- DC line monitoring :
2.2uF Capacitor Transformer type speaker
470uF Capacitor Impedance type speaker
- Transformer type fitted with thermal fuse
- Complies with BS5839 part 8
- Third party tested to IP67 & IP66
- Enclosure material : UL94V0 & 5VA rated FR ABS
- Colour available : Grey (RAL7038)
- Operating temperature : -25 to +55°C
- Storage temperature : -40 to +70°C
- Relative humidity : 90% at 20°C
- Weight : 70/100v line : 2.60kg
Low impedance : 2.20kg

A heavy duty high output IP67 sealed loudspeaker, ideal for harsh environments with high ambient noise levels.

- Large termination area
- 2 x M20 ISO cable gland entries (with 1 blanking plug).
- Ratchet adjustable stainless steel 'U' bracket for 360° positioning.
- All units offer IN & OUT terminals
- Terminals accept 0.5 to 4.0mm² cables.

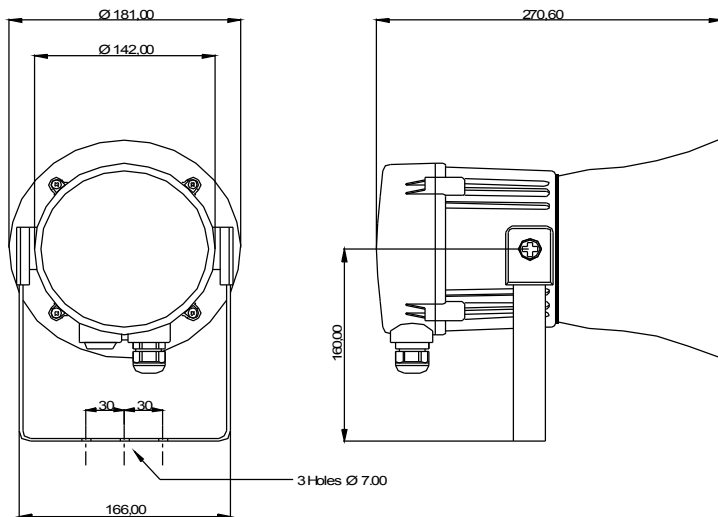

All dimensions are in millimetres.

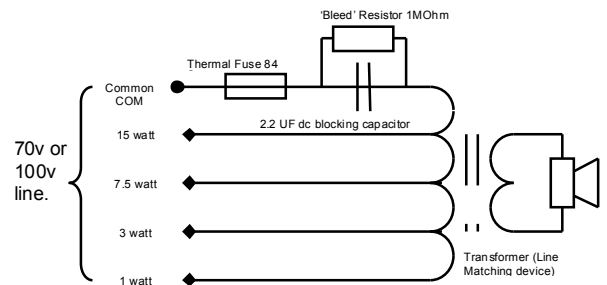

ML15 8 & 16 Ohm low impedance :

Input : 8 Ohm	Power : 15Watts	I/P Volts : 10.95V
Input : 16 Ohm	Power : 15Watts	I/P Volts : 15.49V

Also available :

- **MCA112-05** combined sounder & beacon
- **ML25** 25w marine loudspeaker
- **MA112 & MA121** high output marine sounders
- **MB005 & MB010** 5 and 10 Joule marine beacons
- **MV112** high output marine voice annunciation unit



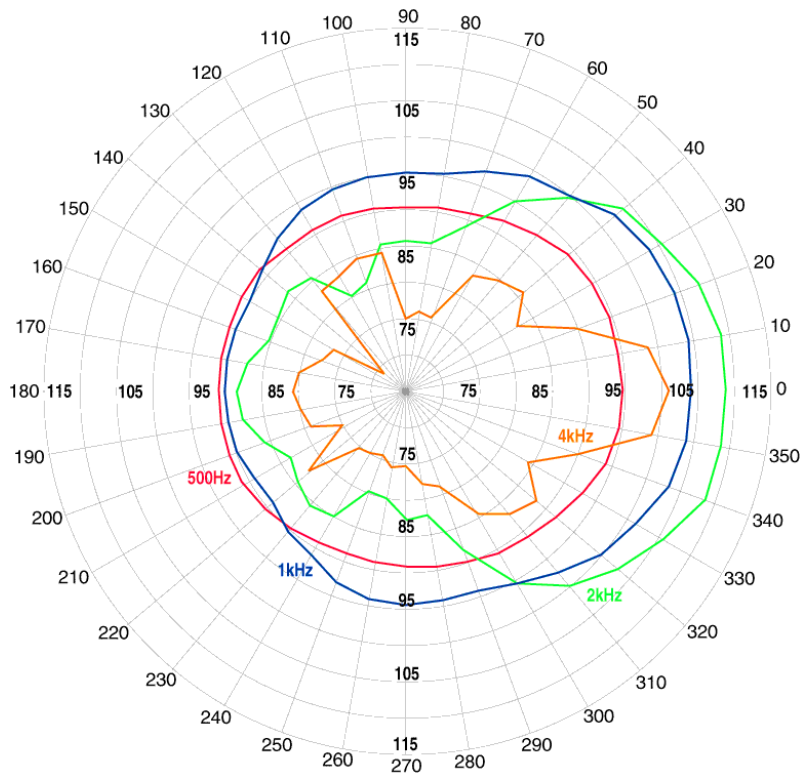
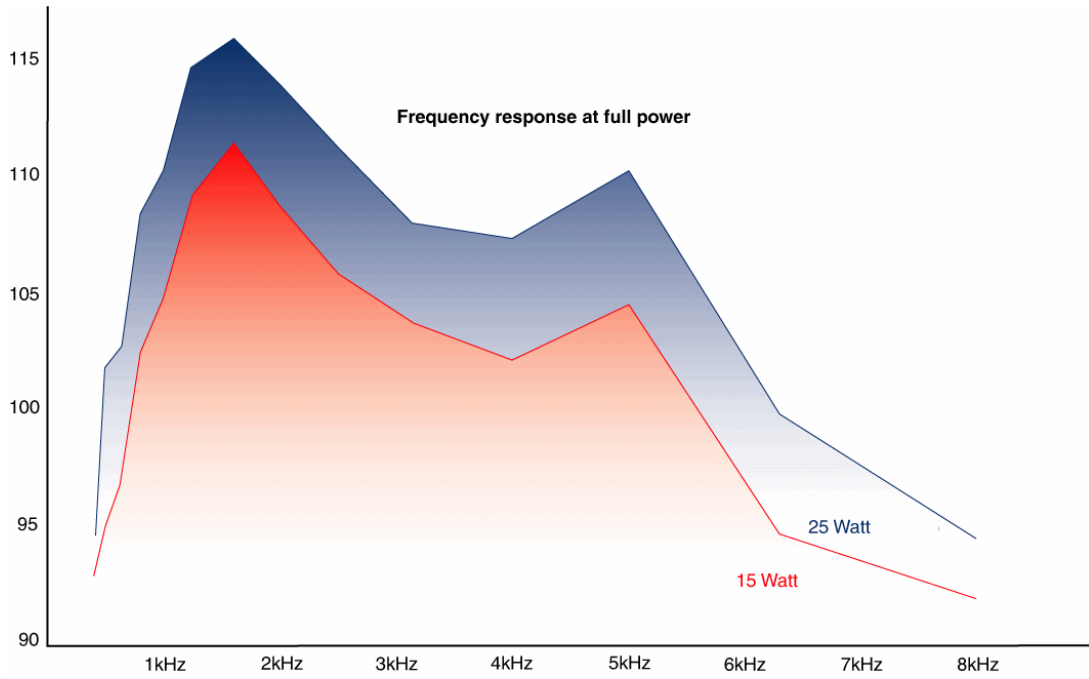

Ordering code :

<u>ML15</u>	<u>100V</u>
Product	Version
ML15	70v Line
	100v Line
	8 Ohm
	16 Ohm

TSP3603-C

No liability is accepted for any consequence of the use of this document. The technical specification of this unit is subject to change without notice due to our policy of continual product development. All dimensions are approximate. This unit is sold subject to our standard conditions of sale, a copy of which is available on request.

Comsec Protection Systems Ltd., Unit 26, Stadium Business Park, Ballycoolin Road, Dublin 11
 PHONE: (01) 8853008 - FAX: +353 (01) 8853007
 EMAIL: info@comsec.ie - WEB: http://www.comsec.ie