



AlarmSense
2-wire
detection
and alarm
system

*Product
Guide*

AlarmSense



Contents

<i>What is AlarmSense?</i>	2
<i>The purpose of AlarmSense</i>	4
<i>How AlarmSense works</i>	4
<i>Alarmsense Features</i>	5
<i>Detector removal monitoring</i>	5
<i>Priority/non-priority sounder setting</i>	5
<i>'Spread of Fire' Detection</i>	5
<i>Detection of manual call point operation</i>	5
<i>Independent disablement of manual call points</i>	5
<i>Multiple LEDs</i>	5
<i>Silencing alarms, resetting detectors and de-activating output devices</i>	5
<i>Optical Detectors</i>	6
<i>Technical Specifications</i>	6
<i>Heat Detectors</i>	6
<i>Technical Specifications</i>	6
<i>AlarmSense Base</i>	7
<i>Technical Specifications</i>	7
<i>Sounder Base</i>	8
<i>Technical Specifications</i>	8
<i>Sounder Beacon Base</i>	8
<i>Technical Specifications</i>	8
<i>Manual Call Point</i>	9
<i>Technical Specifications</i>	9
<i>Alarm Relay (reset on silence)</i>	9
<i>Technical Specifications</i>	9
<i>Control Panel Requirements</i>	10



AlarmSense

What is AlarmSense?

AlarmSense is a range of Apollo conventional fire detection and alarm products specially designed to be connected to the same pair of supply wires in a detection and alarm zone. The range comprises detectors, a manual call point, a sounder, a beacon, a sounder beacon and a relay module.

AlarmSense detectors and devices are powered and controlled by purpose-designed control and indicating equipment. Details can be supplied by Apollo Fire Detectors.

AlarmSense is acceptable for BS 5839-1 systems and BS 5839-6 systems and is therefore particularly useful for fire protection in Houses in Multiple Occupation (HMOs). For more information please refer to the AlarmSense Application Guide: HMO, PP2260.

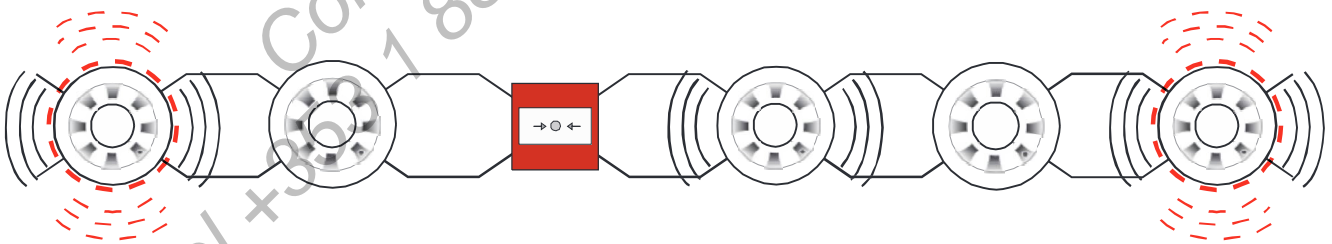

Comsec Protection Systems

The Purpose of AlarmSense

AlarmSense has been developed to make the task of designing and installing a fire detection and alarm system easier and more cost-effective in small to medium-sized buildings. Because it offers greater flexibility it is also ideal for Houses in Multiple Occupation (HMOs).

AlarmSense is

- flexible
- reliable
- cost-effective
- compliant with BS5839
- easy to install
- easy to extend

How AlarmSense works

AlarmSense sounders and manual call points are fitted to the same zone as detectors. In quiescent state the zone is powered at between 9 and 15 volts, nominally 12 volts, at which voltage only detectors and call points operate. Sounders require 24V to operate.

When an alarm is detected on a particular zone, the control panel increases the line voltage to 24V on that zone, causing the sounders to produce a continuous 'Evacuate' sound. Any voltage-sensitive output devices—relay modules or other alarm devices—also operate.

When the voltage is increased to 24V, the detector alarm current will reduce to 1.5mA. The detectors are latched in alarm until they are reset by reducing the voltage to less than 2V for greater than 1 second. Output devices will de-activate each time the voltage is reduced to 12V unless otherwise stated in their specification.

On other zones, where detectors have not changed to the alarm state, generation of the 'Alert' tone can be achieved by pulsing the supply voltage from 12V to 24V with Line 1 positive and the sounders configured to continuous output. Pulse frequency is determined by the control panel but a frequency of 1 second on, 1 second off, is recommended for compliance with BS5839 Pt1.

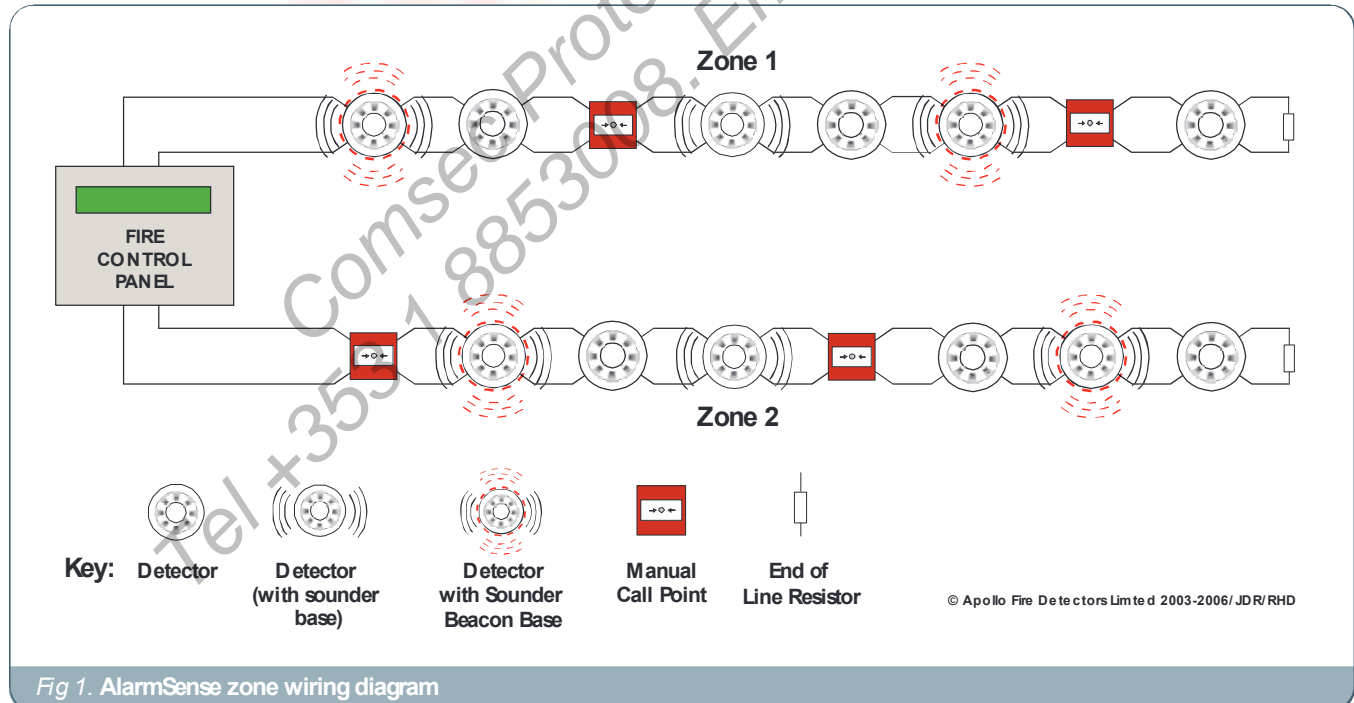

Alarmsense Features

Detector Removal Monitoring

By connecting like-polarity 'zone in' and 'zone out' wires to the same terminal, wiring continuity is maintained in the event of head removal.

Unauthorised removal of a detector head results in the generation of a fault warning. AlarmSense bases monitor the condition of terminal L1 OUT and detection circuitry in the panel registers the pulses generated if a detector is removed.

In the event that a detector has been removed, there will be no loss of power to any sounder base, sounder beacon base or call point, no matter where on the zone they are fitted.

Priority/Non-priority sounder setting

The AlarmSense sounder and sounder beacon base may be switched by means of a DIL switch to provide either a general or a local alarm. In an HMO the sounder or sounder beacon could be set to non-priority to give a local alarm in individual flats or apartments while the devices in communal and circulation areas and escape routes are set to priority to give a general alarm.

In the event of a detector in an apartment changing to the alarm state the control panel would switch the associated sounder or sounder beacon to non-priority alarm. This will warn the occupants who then have 2 minutes to investigate and remove any cause of false alarm, such as overheating food in the kitchen.

If the cause of the alarm is cleared within 2 minutes the system will reset. If the detector is still activated after 2 minutes the system will switch all sounders to full alarm.

- Notes:**
1. The operation of an AlarmSense Manual Call Point will always trigger a priority (general) alarm to warn all building occupants of a fire.
 2. Apollo recommends that, when a heat detector is fitted to a sounder base or sounder beacon base, the sounder be set only as a 'Priority' sounder.

'Spread of Fire' Detection

It is possible to check to ascertain whether additional detectors (in other zones) have changed to the alarm state as a fire spreads.

This is done either by interrupting the 'evacuate' tone for a period of no longer than 15ms and applying 12V to the line or by sensing during the 1 second off period of the 'Alert' tone.

Any detectors in alarm will increase their current to 25mA for this 15ms period.

Detection of manual call point operation

AlarmSense manual call points are polarity sensitive in order that they may be disabled independently of sounders or detectors. In addition, call points switch to the 25mA alarm current at a lower voltage than detectors (approx 3V below), hence it is possible to identify call point operation, even if detectors are in the alarm condition.

Independent disablement of manual call points

Manual call points may be disabled independently of detectors by reversing the zone voltage.

Multiple LEDs

The zone output should be current limited to approximately 20mA at voltages below 18V. This will ensure that there is sufficient, but not excessive, current available to keep LEDs illuminated when multiple detectors are in alarm, due to the spread of fire.

Silencing alarms, resetting detectors and de-activating output devices

To silence alarms, reduce the line voltage to <15V (12V nominal) for at least 2 seconds.

To reset detectors in the alarm condition, reduce the line voltage to less than 2V for at least 1 second.

Depending upon their individual specifications, the various AlarmSense output devices will either de-activate at less than 15V or may require the line voltage to be reduced to less than 2V in order to perform a reset.

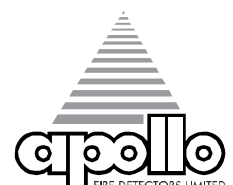

Comsec Protection Systems



AlarmSense optical detector Part no 55000-390



AlarmSense heat detector Part no 55000-190 (A1R)
55000-193 (CS)

Optical Detectors

AlarmSense optical detectors work on the light scatter principle.

They change to the alarm state at a pre-set threshold of smoke penetration into the sensing chamber.

Heat Detectors

Heat detectors are classified according to the requirements of EN54, part 5. The AlarmSense range includes one rate-of-rise heat detector and one static (fixed-temperature) detector.

TECHNICAL SPECIFICATIONS

Operating voltage range	9–33V
Polarity	polarity insensitive
Quiescent current at 15V	<50µA
Alarm current at	
2–8.5V	<1.5mA
10.5–15V	25 ± 2mA
18–24V	<1.5mA
33V	<2mA
Maximum reset voltage	2V
Reset time	1s
Max supply interruption time	40ms
EMC	CE marked to EN50130-4
Dimensions	100mm diameter x 42mm detector in base 100mm diameter x 50mm
Weight	100g

Detectors are housed in standard Apollo pure white polycarbonate mouldings, and fitted with two LEDs in order to allow 360° visibility.

An integrating optical detector, part no 55000-391, is available for use in areas where smoke is present as a result of normal activity. Residents of a House in Multiple Occupation (HMO) might be smokers and the integrating detector would help avoid false alarms.

TECHNICAL SPECIFICATIONS

Operating voltage range	9–33V
Polarity	polarity insensitive
Quiescent current at 15V	<50µA
Alarm current at	
2–8.5V	<1.5mA
10.5–15V	25 ± 2mA
18–24V	<1.5mA
33V	<2mA
Maximum reset voltage	2V
Reset time	1s
Max supply interruption time	40ms
Available grades	A1R & CS
EMC	CE marked to EN50130-4
Dimensions	100mm diameter x 42mm detector in base 100mm diameter x 50mm
Weight	100g

Detectors are housed in standard Apollo pure white polycarbonate mouldings, and fitted with two LEDs in order to allow 360° visibility.



AlarmSense mounting base

Part no 45681-244

AlarmSense Base

AlarmSense detectors may be mounted only into AlarmSense bases. These bases are fitted with electronic circuitry to monitor the presence of detectors and allow a fault to be signalled if a detector is removed without authorisation. This is also the case with the sounder bases and the sounder beacon bases.

TECHNICAL SPECIFICATIONS

Quiescent current, detector head fitted	<3µA
Load presented to zone, head removed	47Ω for 10ms every 4 seconds
Dimensions	100mm diameter
Weight	55g

Warning: do not use Series 65 detectors on AlamSense systems. Although they might appear to work initially, their use could cause severe system malfunction. If used with the sounder or sounder beacon base the non-priority function will not operate correctly.

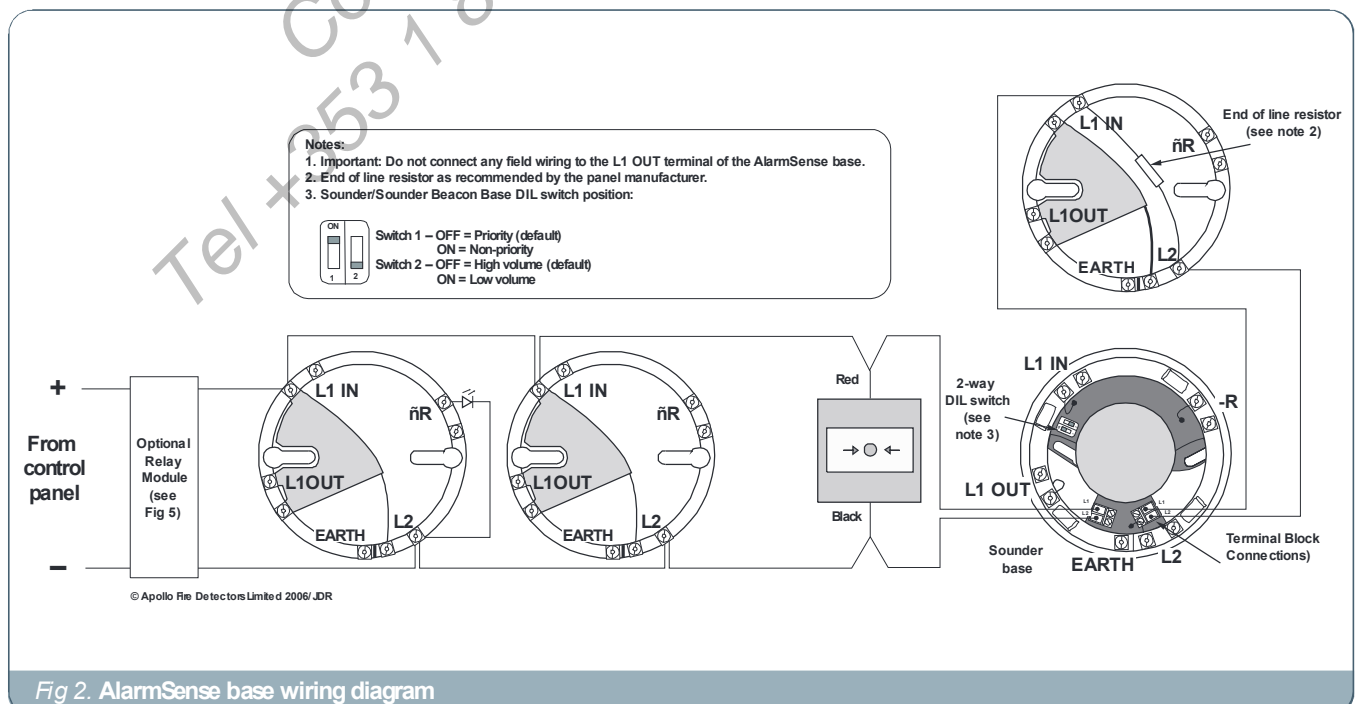

Fig 2. AlarmSense base wiring diagram

Comsec Protection Systems



AlarmSense sounder base

Part no 45681-510



AlarmSense sounder beacon base

Part no 45681-509

Sounder Base

TECHNICAL SPECIFICATIONS

<i>Sound output (SPL) at 24V, DIL-switch selectable</i>	
<i>High volume setting, maximum</i>	87dB(A)
<i>Low volume setting, nominal</i>	70dB(A)
<i>Polarity</i>	<i>polarity insensitive</i>
<i>Operating voltage</i>	<i>sounders active, 18–33V</i>
	<i>sounders off, <15V</i>
<i>Quiescent current at 12V</i>	<20µA
<i>Sounder active current at 24V</i>	5mA
<i>Head removal load</i>	47ÿ for 10ms every 4s

EMC	CE marked to EN50130-4
Dimensions	115 diameter x 40 mm
Weight	150g
Housing	white polycarbonate moulding red or white caps available

Notes:

1. For wiring diagram please see Fig 2, page 7.
2. Priority/non-priority signalling.
3. High/low volume setting.
4. Sounder base monitors for head removal. If used as a stand-alone sounder a wire link must be fitted between L1IN and L1OUT.
5. Remote LED indicators may not be used in conjunction with this sounder base.
6. Red or white caps are available for stand-alone installation.

Sounder Beacon Base

TECHNICAL SPECIFICATIONS

<i>Sound output (SPL) at 24V, DIL-switch selectable</i>	
<i>High volume setting, maximum</i>	87dB(A)
<i>Low volume setting, nominal</i>	70dB(A)
<i>Polarity</i>	<i>polarity insensitive</i>
<i>Operating voltage</i>	<i>sounders active, 18–33V</i>
	<i>sounders off, <15V</i>
<i>Quiescent current at 12V</i>	<20µA
<i>Sounder active current at 24V</i>	5mA
<i>Head removal load</i>	47ÿ for 10ms every 4s

EMC	CE marked to EN50130-4
Dimensions	115 diameter x 40 mm
Weight	150g
Housing	white polycarbonate moulding red or white caps available

Notes:

1. For wiring diagram please see Fig 2, page 7.
2. Priority/non-priority signalling.
3. High/low volume setting.
4. Sounder base monitors for head removal. If used as a stand-alone sounder a wire link must be fitted between L1IN and L1OUT.
5. Remote LED indicators may not be used in conjunction with this sounder base.
6. Red or white caps are available for stand-alone installation.



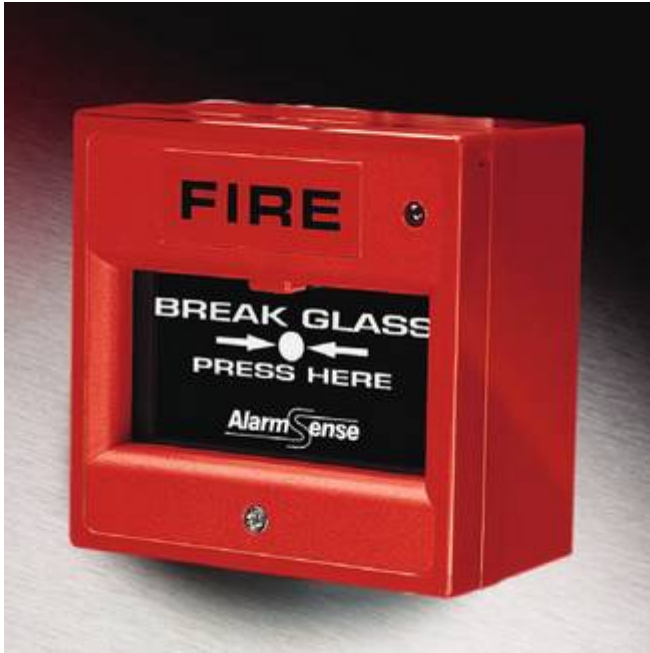

AlarmSense manual call point

Part no 55000-894



AlarmSense Alarm relay (reset on silence) Part no 55000-835

Manual Call Point

The AlarmSense Manual Call Point is different from other conventional call points in that it can be detected as an operated call point rather than a detector that has changed to the alarm state.

TECHNICAL SPECIFICATIONS

Operating voltage range	9–33V
Polarity	polarity insensitive
Quiescent current at 15V	<50µA
Alarm current at	
2–8.5V	<1.5mA
10.5–15V	25 ± 2mA
18–24V	<1.5mA
33V	<2mA
Maximum reset voltage	2V
Reset time	1s
LED indicator	red
Maximum supply interruption	40ms
EMC	CE marked to EN50130-4
Dimensions	87x87x52mm
Material	KAC Class 6000 in RED Cyclopol C2800 polycarbonate/ ABS moulding
Weight	170g

Alarm Relay (reset on silence)

The Alarm Relay operates in three configurations:

- relay activation places AlarmSense zone voltage on the output contact terminals.
- relay activation reverses the polarity of the AlarmSense zone voltage on the output contact terminals. This mode is designed to allow the use of monitored conventional sounders fitted with series diodes.
- two sets of volt-free contacts for use by door closure units, etc.

TECHNICAL SPECIFICATIONS

Operating voltage	9–33V
Polarity	polarity insensitive
Relay operation voltage	>18V
Relay reset voltage	>15V
Quiescent current at 12V	<20µA
Surge current at relay set voltage	15mA for 20ms
Relay set current at 24V	<120µA
Relay contact ratings	1A at 30V DC
Dimensions	65x45x25mm
Weight	35g

Notes:

1. Power loss on the AlarmSense circuit will cause the relay to reset. In the event of the relay being activated during transit, the status of the relay is unknown. This then places the onus on the commissioning engineer to check and, if necessary, reset the relay by increasing the zone voltage to 24V for >2s and then reducing the zone voltage back to 12V.
2. DIL switch selectable relays reset delay:
OFF = no delay ON = 2s delay.
3. The Alarm Relay will, by switching a DIL switch, recognise non-priority signals from the control panel. It could, therefore, be used to activate a staff alarm or a stand-alone alarm indicator.

Control Panel Requirements

AlarmSense detectors and other devices depend for their operation on the ability of the control and indicating equipment to switch between several different operating voltages. Control and indicating equipment must, therefore, be designed for the specific purpose of powering and controlling AlarmSense detectors, manual call points, sounders and other devices and must meet the requirements listed below. Standard control panels will not be able to power and control AlarmSense equipment.

1. In the quiescent state the 12V supply should have an output impedance of 220 ohms or be current-limited to 20mA.
2. The period for which the zone supply is switched from 24v to 12V to check for operation of a detector while sounders are operating should not exceed 15ms.
3. Reset time must be at least 1s.
5. Output impedance at 24V should be suitable for the alarm load.
6. The switching time from 12V to 24V must not exceed 5ms.

AlarmSense



Comsec Protection Systems.
Tel +353 1 8853008. Email info@comsec.ie



Comsec Protection Systems.
Tel +353 1 8853008. Email info@comsec.ie



© Apollo Fire Detectors Ltd 2007



Assessed to ISO 9001: 2000
Certificate number 010



36 Brookside Road, Havant, Hampshire PO9 1JR, England. Tel: +44 (0)23 9249 2412. Fax: +44 (0)23 9249 2754.

Email: sales@apollo-fire.co.uk Website: www.apollo-fire.co.uk

26 Stadium Business Park, Ballycoolin Rd. Dublin 11
Tel. +353 (0) 1 8853008 www.comsec.ie info@comsec.ie