

BExCP3A/B-PT Tool Reset Call Point

The BExCP3A-PT and BExCP3B-PT push button, tool resettable manual call points are approved for Zone 1, 2, 21 and 22 hazardous areas for the control of fire and gas alarm systems. Available with and without monitoring resistors all versions are certified to ATEX and IECEx standards.

The push button mechanism is protected by a spring loaded cover therefore the switch requires a two-action activation. The push button is user resettable via the use of the special key supplied with the unit. The BEx range features enclosures manufactured from corrosion proof, marine grade, copper free LM6 (A413) aluminium which is phosphated and powder coated.

Specification:

BExCP3A-PT:	II 2G Ex e d IIC T6 Gb II 2D Ex t IIIC T60°C Db IP66
BExCP3B-PT:	II 2G Ex e d mb IIC T4 Gb II 2D Ex t IIIC T70°C Db IP66
Ambient:	Ta = -40°C to +55°C (+50°C for BExCP3B)
Ingress protection:	IP66
Housing material:	Marine grade copper free LM6 Aluminium
Housing finish:	Phosphated & powder coated finish: anti-corrosion.
Colour:	RAL3000 Red (others available on request)
Cable entries:	2 x M20 clearance top and 1 x M20 clearance side. Back box can be rotated to give 2 x bottom and 1 x side entries.
Stopping plugs:	2 x Ex e nylon plugs as standard Brass and stainless steel plugs optional
Terminals:	6 x 4.0mm ² cables.

Options:

- Alternative housing colours are available to meet specific requirements.
- DIN rail mounted terminal blocks: 8 x 2.5mm²
- Metalised Polyester "Duty" label.
- Series and/or End of Line resistors.

Approvals:

- ATEX certificate: Sira 09ATEX3286X, IEC 60079-0:2007 Ed 5, EN 60079-1:2004, EN 60079-7:2007, IEC 60079-18:2009 Ed 3, EN 61241-1:2004
- IECEx certificate: IECEx SIR 09.0121X, IEC 60079-0:2007-10 Edition: 5, IEC 60079-1:2003 Edition: 5, IEC 60079-18:2009 Edition: 3, IEC 60079-7:2006-07 Edition: 4, IEC 61241-1:2004 Edition: 1
- Inmetro certificate: 10-IE-0011X



COMSEC PROTECTION SYSTEMS LTD.
UNIT 26, STADIUM BUSINESS PARK, • BALLYCOOLIN ROAD, • DUBLIN 11, • IRELAND
PHONE: +353 (0)1 8853008 • FAX: +353 (0)1 8853007
EMAIL: info@comsec.ie • WEB: <http://www.comsec.ie>

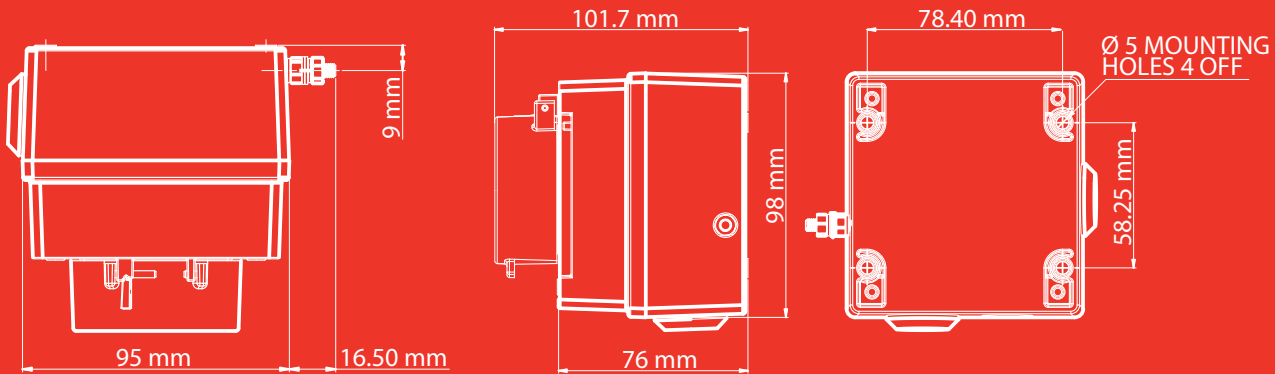

Versions:

Version:	Category:	Voltage:	Switch rating:	Monitoring Resistors:	Terminals:	Cable entries:	Weight:		
BExCP3A-PT	II 2G Ex e d IIC T6 Gb	250V ac Max.	5.0A Max.	N	6 x 4mm ²	2 x M20	0.8Kg		
	II 2D Ex t IIIC T60°C Db	50V dc Max.	1.0A Max.			Top/Bottom			
	IP66					1 x M20			
	Ta = -40°C to +55°C					Left/Right			
			Nominal Voltage:	Maximum Voltage:	Min. EOL / Series Value:				
BExCP3B-PT	II 2G Ex e d mb IIC T4 Gb	56V dc Max.	48V	56V	1K8	Y	6 x 4mm ²	2 x M20	0.8Kg
	II 2D Ex t IIIC T70°C Db	Rating:	24V	28V	470R		or	Top/Bottom	
	IP66	<50V: 1.0A	12V	15V	120R		8 x 2.5mm ²	1 x M20	
	Ta = -40°C to +50°C	>50V: 0.75A	6V	9V	47R		DIN rail	Left/Right	

Part Codes:

Type:	Terminals:	Duty Label:	Colour:	Nominal Voltage	E.O.L Resistor:	Series Resistor:
BExCP3A-PT	ST	NL	RD	48V	ExxxR	SxxxR
BExCP3B-PT	DR	DL		24V		
				12V		
				6V		

ST: Standard
DR: DIN rail
'DR' option
only on BExCP3B
version

NL: No label (std)
DL: Duty Label
Specify content

RD: Red (std)
Contact sales
for other
when ordering.

System Voltage
only required
on BExCP3B
colour options

xxx: Res. value
e.g.: E470R
Only available on
BExCP3B version

xxx: Res. value
e.g.: S2K2R
Only available on
BExCP3B version

e.g. BExCP3A-PT-ST-NL-RD

: BEx-CP3A Tool Reset call point with standard terminals and no duty label. Red housing

e.g. BExCP3B-PT-DR-NL-RD-24V-E470R

: BEx-CP3B Tool Reset call point with DIN rail terminals, no duty label, 24V supply voltage with a 470 Ohm end of line resistor. Red housing.

COMSEC PROTECTION SYSTEMS LTD.

UNIT 26, STADIUM BUSINESS PARK, • BALLYCOOLIN ROAD, • DUBLIN 11, • IRELAND
PHONE: +353 (0)1 8853008 • FAX: +353 (0)1 8853007
EMAIL: info@comsec.ie • WEB: <http://www.comsec.ie>

Once testing is complete the unit needs to be reset from the operated condition.

Using the special reset tool provided the tool reset button is rotated anticlockwise by an angle of 55°, see guide alignment marks on button and cover, shown below (1). The tool reset button should pop back up to its original position.

Ensure that the tool reset button has also twisted back clockwise by 55° to its original position see guide marks on button and cover, shown below (2). The unit is now reset.

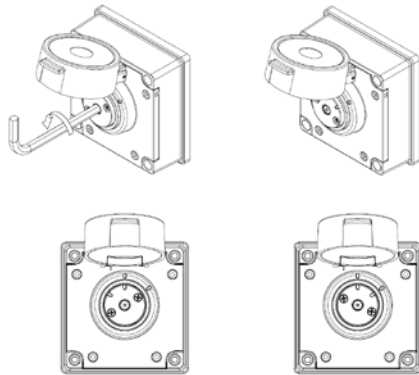

1. On operated unit
Twist tool reset button
Anticlockwise 55°
with special key to reset

2. Button should pop
up and twist back to
original position

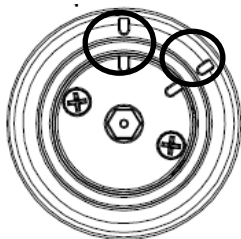

Note: use
alignment marks
circled to indicate
the tool reset
buttons status
/position.

Unit currently
shown as 'standby
condition'

Resetting an operated unit is the same as resetting a tested unit.

BExCP3A-PT
Manual Call Point – Tool Reset
For use in Flammable Gas and
Combustible Dust Atmospheres

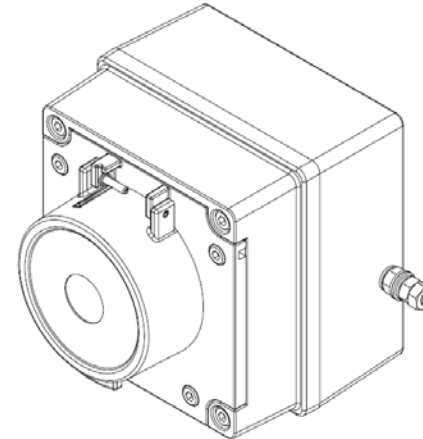

1) Introduction

The BExCP3A-PT is a tool reset manual call point which is certified to the European and International Gas and Dust standards. The unit meets the requirements of the ATEX directive 94/9/EC and IECEx scheme.

The call point can be used in hazardous areas where potentially flammable gas and dust atmospheres may be present.

The BExCP3A-PT has no monitoring resistors. The units are Group II, EPL (equipment protection level) Gb. The equipment is certified 'Ex e d IIC T6 Gb' and as such may be used in Zones 1 and 2 with flammable gases and vapours with gas groups IIA, IIB & IIC and temperature classes T1, T2, T3, T4, T5 and T6.

These units are also Group III, EPL Db. The equipment is certified 'Ex t IIIC T60°C Db' and as such may be used in Zones 21 and 22 for combustible dusts groups IIIA, IIIB & IIIC.

2) Marking

All units have a rating label, which carries the following important information:-

Unit Type No.:
BExCP3A-PT Manual Call Point

Input Voltage:
AC voltage 250V Max Current 5.0A Max
DC voltage 50V Max Current 1.0A Max

Code:
Ex e d IIC T6 Gb
Ex t IIIC T60 °C Db
IP66
-40°C ≤ Ta ≤ +55°C

Certificate No.:
SIRA 09ATEX3286X
IECEx SIR 09.0121X

Epsilon x:  II 2GD

CE Marking
Notified body No.  0518

Year/Serial No. i.e. 09/1CP3APT000001

**WARNING - DO NOT OPEN WHEN AN
EXPLOSIVE ATMOSPHERE MAY BE PRESENT**

3) Type Approval Standards

The beacon has an EC Type examination certificate issued by SIRA and have been approved to the following standards:-

IEC 60079-0:2007
EN 60079-1:2004 / IEC 60079-1:2003
EN 60079-7:2007 / IEC 60079-7:2006
IEC 60079-18:2009

EN 61241-1:2004 / IEC 61241-1:2004

The equipment is certified for use in ambient temperatures in the range -40°C to +55°C and shall not be used outside this range.

4) Installation Requirements

Installation of this equipment shall only be carried out by suitably trained personnel in accordance with the applicable code of practice e.g.

IEC 60079-14/EN 60079-14 and IEC 61241-14/EN 61241-14.

9) Repair of this equipment shall only be carried out by the manufacturer or in accordance with the applicable code of practice e.g. IEC 60079-19/EN 60079-19.

10) The certification of this equipment relies on the following materials used in its construction:

Enclosure: Aluminium Pressure Die Cast Body LM6

Through enclosure mechanism: Plastic Nylon Zytel Injection Moulded

Sealing of enclosure and mechanism: O-ring Acrylonitrile-Butadiene Rubber

Potting Compound of resistors where used: Epoxy Resin

If the equipment is likely to come into contact with aggressive substances, then it is the responsibility of the user to take suitable precautions that prevent it from being adversely affected, thus ensuring that the type of protection is not compromised.

“Aggressive substances” - e.g. acidic liquids or gases that may attack metals, or solvents that may affect polymeric materials.

“Suitable precautions” - e.g. regular checks as part of routine inspections or establishing from the material’s data sheet that it is resistant to specific chemicals.

Refer to certificates SIRA 09ATEX3286X and IECEx SIR 09.0121X for special conditions of safe use.

5) Call Point Location and Mounting

The location of the call point should enable ease of access for operation and testing. The unit should be mounted using the 4 off fixing holes which will accept up to M4 sized fixings.

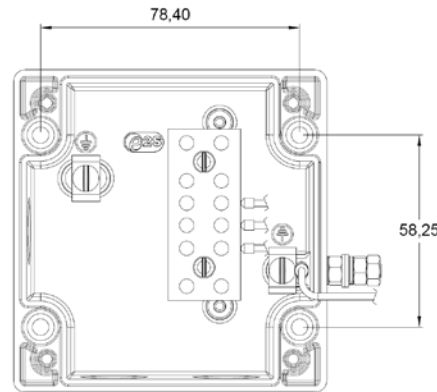

View of base unit showing fixing centres.

To gain access to the mounting holes in the base the front cover must be removed.

This is achieved by removing the 4 off M4 cap head bolts holding on the cover.

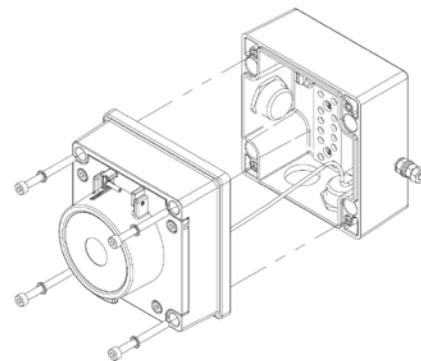

Once the screws are removed the cover will hang down out of the way to gain access to the Ex e terminal block, the internal earth terminal and mounting hole recesses.

6) Earthing

The unit has both internal and external earth terminals.

It is recommended that a cable crimp lug is used on the earth wires.

The internal earth wire is placed under a earth clamp which will stop the cable twisting. This is secured by an M4 screw and spring washer.

The external earth lug should be located between the two M5 washers provided and securely locked down with the M5 spring washer and two locknuts.

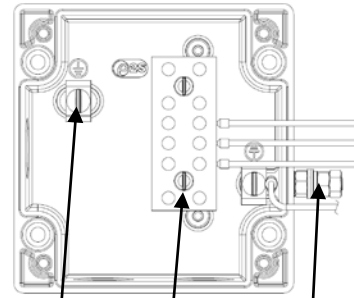

Internal Earth terminal

External Earth Stud

Ex e terminal block

7) Cable connections

There are 3 off cable entries for M20x1.5 Ex e approved cable glands or stopping plugs

The unit can be wired in a number of different ways depending whether normally open or normally closed contacts are required.

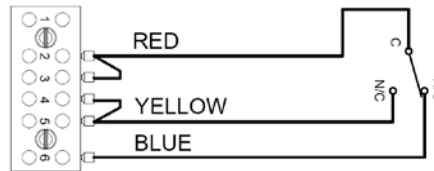

Unit in 'Standby condition' unoperated

Terminal (2,3) & (6) switch contacts closed
Terminals (2,3) & (4,5) switch contacts open

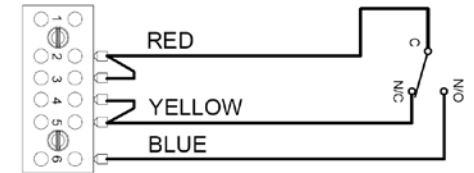

Unit in 'Operated condition' (broken glass)

microswitch contacts changed over
Terminal (2,3) & (6) switch contacts open
Terminals (2,3) & (4,5) switch contacts closed

When wiring to Increased Safety terminal enclosures, you are only permitted to connect one wire into each way on the terminal block, unless a pair of wires are crimped into a suitable ferrule.

8) Testing unit operation

The tool reset unit can be tested without the need to replace any element.

To test, lift the cover lift flap to reveal the tool reset button. The button should be pressed into the body to activate the unit and place it into the operated condition.

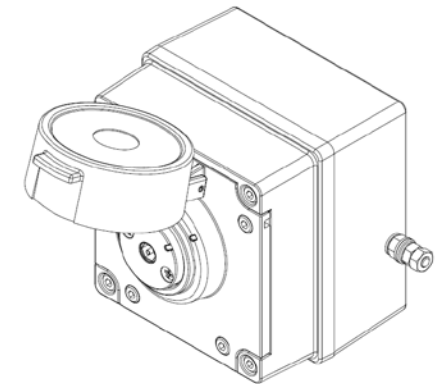

The call point switch will now change over it's contacts to operate the alarm.

8) Testing unit operation

The tool reset unit can be tested without the need to replace any element.

To test, lift the cover lift flap to reveal the tool reset button. The button should be pressed into the body to activate the unit and place it into the operated condition.

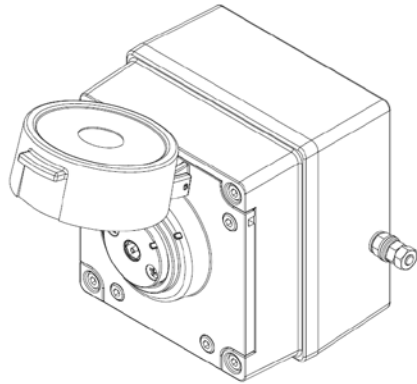

The call point switch will now change over its contacts to operate the alarm. Once testing is complete the unit needs to be reset from the operated condition.

Using the special reset tool provided the tool reset button is rotated anticlockwise by an angle of 55°, see guide alignment marks on button and cover, shown below (1). The tool reset button should pop back up to its original position. Ensure that the tool reset button has also twisted back clockwise by 55° to its original position see guide marks on button and cover, shown below (2). The unit is now reset.

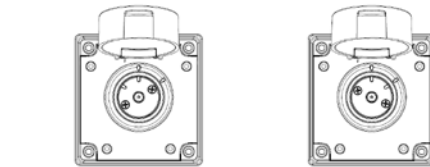
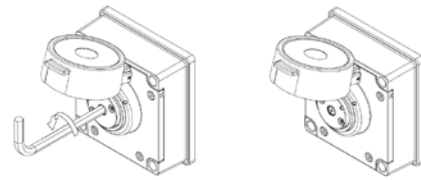

1. On operated unit
Twist tool reset button
Anticlockwise 55°
with special key to reset

2. Button should pop up and twist back to original position

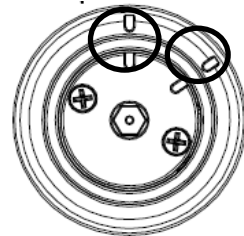

Note: use alignment marks circled to indicate the tool reset buttons status /position.

Unit currently shown as 'standby condition'

Resetting an operated unit is the same as resetting a tested unit.

BExCP3B-PT
Manual Call Point – Tool Reset
With Resistor Modules
For use in Flammable Gas and
Combustible Dust Atmospheres

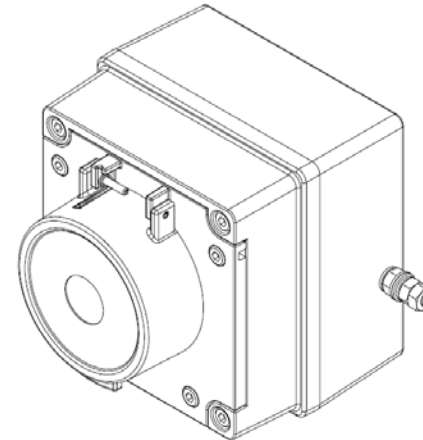

1) Introduction

The BExCP3B-PT is a tool reset manual call point which is certified to the European and International Gas and Dust standards. The unit meets the requirements of the ATEX directive 94/9/EC and IECEx scheme.

The call point can be used in hazardous areas where potentially flammable gas and dust atmospheres may be present.

The BExCP3B-PT has up to two monitoring resistors. The units are Group II, EPL (equipment protection level) Gb. The equipment is certified 'Ex e d mb IIC T4 Gb' and as such may be used in Zones 1 and 2 with flammable gases and vapours with gas groups IIA, IIB & IIC and temperature classes T1, T2, T3 and T4.

These units are also Group III, EPL Db. The equipment is certified 'Ex t IIIC T70°C Db' and as such may be used in Zones 21 and 22 for combustible dusts groups IIIA, IIIB & IIIC.

2) Marking

All units have a rating label, which carries the following important information:-

Unit Type No.:
BExCP3B-PT Manual Call Point

Input Voltages:
 48VDC nominal 56VDC Max 0.75Amax
 24VDC nominal 28VDC Max 1.0A Max
 12VDC nominal 15VDC Max 1.0A Max
 6VDC nominal 9VDC Max 1.0A Max

Code:
 Ex e d mb IIC T4 Gb
 Ex t IIIC T70 °C Db
 IP66
 -40°C ≤ Ta ≤ +50°C

Certificate No.:
 SIRA 09ATEX3286X
 IECEX SIR 09.0121X

Epsilon x:  II 2GD

CE Marking
 Notified body No.  0518

Year/Serial No. i.e. 09/1CP3BPT000001

WARNING - DO NOT OPEN WHEN AN EXPLOSIVE ATMOSPHERE MAY BE PRESENT

3) Type Approval Standards

The beacon has an EC Type examination certificate issued by SIRA and have been approved to the following standards:-

IEC 60079-0:2007
 EN 60079-1:2004 / IEC 60079-1:2003
 EN 60079-7:2007 / IEC 60079-7:2006
 IEC 60079-18:2009

EN 61241-1:2004 / IEC 61241-1:2004

The equipment is certified for use in ambient temperatures in the range -40°C to +50°C and shall not be used outside this range.

4) Installation Requirements

Installation of this equipment shall only be carried out by suitably trained personnel in accordance with the applicable code of practice e.g. IEC

60079-14/EN 60079-14 and IEC 61241-14/EN 61241-14.

9) Repair of this equipment shall only be carried out by the manufacturer or in accordance with the applicable code of practice e.g. IEC 60079-19/EN 60079-19.

10) The certification of this equipment relies on the following materials used in its construction:

Enclosure: Aluminium Pressure Die Cast Body LM6

Through enclosure mechanism: Plastic Nylon Zytel Injection Moulded

Sealing of enclosure and mechanism: O-ring Acrylonitrile-Butadiene Rubber

Potting Compound of resistors where used: Epoxy Resin

If the equipment is likely to come into contact with aggressive substances, then it is the responsibility of the user to take suitable precautions that prevent it from being adversely affected, thus ensuring that the type of protection is not compromised.

“Aggressive substances” - e.g. acidic liquids or gases that may attack metals, or solvents that may affect polymeric materials.

“Suitable precautions” - e.g. regular checks as part of routine inspections or establishing from the material’s data sheet that it is resistant to specific chemicals.

Refer to certificates SIRA 09ATEX3286X and IECEX SIR 09.0121X for special conditions of safe use.

5) Call Point Location and Mounting

The location of the call point should enable ease of access for operation and testing. The unit should be mounted using the 4 off fixing holes which will accept up to M4 sized fixings.

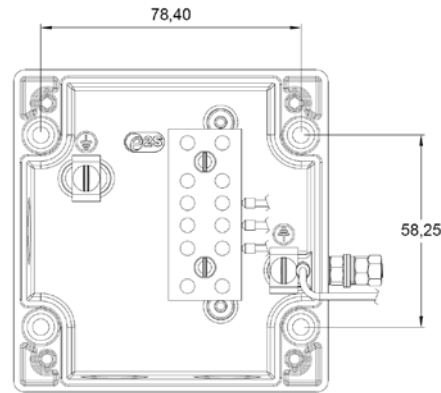

View of base unit showing fixing centres.

To gain access to the mounting holes in the base the front cover must be removed.

This is achieved by removing the 4 off M4 cap head bolts holding on the cover.

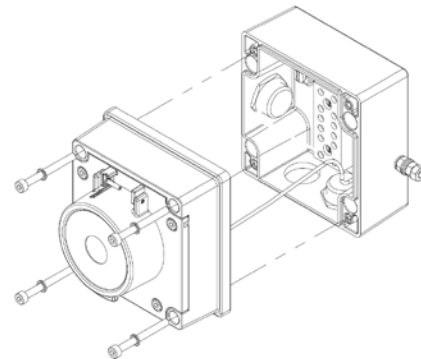

Once the screws are removed the cover will hang down out of the way to gain access to the Ex e terminal block, the internal earth terminal and mounting hole recesses.

6) Earthing

The unit has both internal and external earth terminals.

It is recommended that a cable crimp lug is used on the earth wires.

The internal earth wire is placed under a earth clamp which will stop the cable twisting. This is secured by an M4 screw and spring washer.

The external earth lug should be located between the two M5 washers provided and securely locked down with the M5 spring washer and two locknuts.

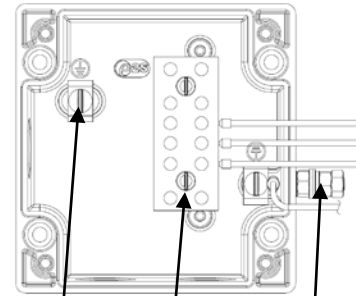

Internal Earth terminal

Ex e terminal block

External Earth Stud

7) Cable connections

There are 3 off cable entries for M20x1.5 Ex e approved cable glands or stopping plugs

The unit can be wired in a number of different ways depending on the resistor combination selected.

Option 1 – In line resistor R1

Option 2 – End of line resistor R2

Option 3 – In line and end of line resistors R1 & R2

Note:- The maximum voltage stated must not be exceeded, as the internal resistor modules are rated as compliant with Ex mb according to the units voltage

When wiring to Increased Safety terminal enclosures, you are only permitted to connect one wire into each way on the terminal block, unless a pair of wires are crimped into a suitable ferrule

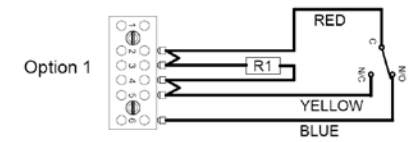

Option 1

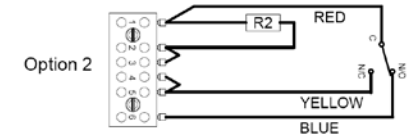

Option 2

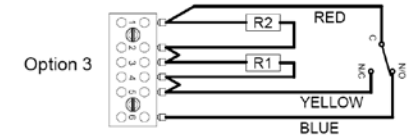

Option 3

Unit in ‘Standby condition’ unoperated
Terminals (2,3) & (6) switch contacts closed
Terminals (2,3) & (4,5) switch contacts open

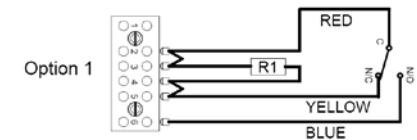

Option 1

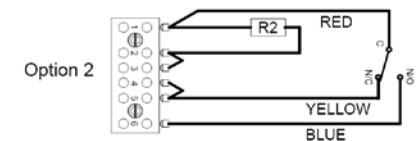

Option 2

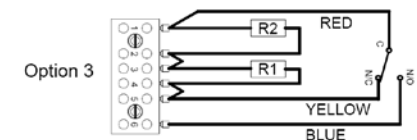

Option 3

Unit in ‘Operated condition’ (broken glass)
microswitch contacts changed over
Terminals (2,3) & (6) switch contacts open
Terminals (2,3) & (4,5) switch contacts closed