

ML15 PA Horn Loudspeaker

The ML15 15W PA loudspeaker features a robust, fire retardant, IP66 & IP67 housing; suitable for harsh environments with high ambient noise levels.

COMSEC PROTECTION SYSTEMS LTD.

UNIT 26, STADIUM BUSINESS PARK, • BALLYCOOLIN ROAD, • DUBLIN 11, • IRELAND

PHONE: +353 (0)1 8853008 • FAX: +353 (0)1 8853007

EMAIL: info@comsec.ie • WEB: <http://www.comsec.ie>

Features:

- Continuously rated.
- Large termination area.
- Stainless steel fixings.
- Ratchet adjustable stainless steel 'U' bracket for 360° positioning.
- Duplicate cable terminations (in & out for daisy-chain installations).
- Tropicalisation available on request.

Part codes:

Version:	Part code:
100V Line	ML15W100VG
70V Line	ML15W70VG
16 Ohm	ML15W16RG
8 Ohm	ML15W8RG



Approvals:

- UKOOA/PFEER compliant alarm tones.
- GOST-R approved. Cert: POCC GB-JB05-B02228



Also available as the MCL15-05 15W PA Loudspeaker with Xenon beacon.



COMSEC PROTECTION SYSTEMS LTD.

UNIT 26, STADIUM BUSINESS PARK, • BALLYCOOLIN ROAD, • DUBLIN 11, • IRELAND
PHONE: +353 (0)1 8853008 • FAX: +353 (0)1 8853007
EMAIL: info@comsec.ie • WEB: http://www.comsec.ie

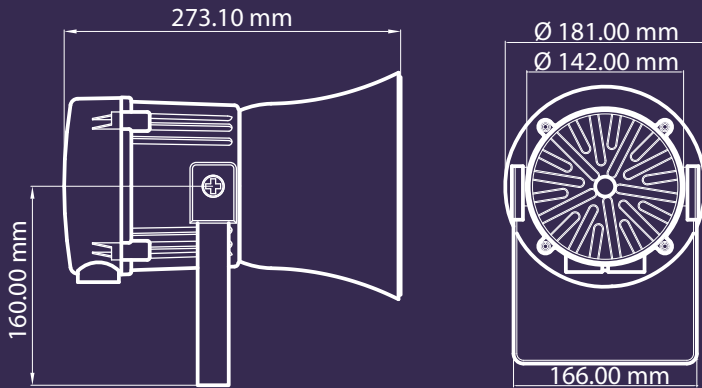

Specification:

SPL:	108dB +/-3dB @ 1w @ 1m - Pink noise 118dB +/-3dB @ 15w (rated power) @ 1m
Rated power:	15 Watts RMS
70v line tapings:	15w / 7.5w / 3w / 1w (z=336.67 Ohms / 653.33 Ohms / 1.6kOhms / 4.9kOhms)
100v line tapings:	15w / 7.5w / 3w / 1w (z=666.87 Ohms / 1.34kOhms / 3.34kOhms / 10kOhms)
Low impedance:	8 Ohm or 16 Ohm
Dispersion:	120° @ 1kHz & 32° @ 4kHz
Frequency range:	400Hz to 8000 Hz
DC Line monitoring:	2.2uF Capacitor (Transformer version) 470uF Capacitor (Low impedance version)
Ingress protection:	IP66 & IP67 (Third party tested)
Housing material:	High impact UL94 V0 & 5VA FR ABS
Colour:	Grey (RAL7038)
Cable entries:	2 x M20 supplied with 1 blanking plug
Terminals:	0.5 to 4.0mm ² cables.
Operating temperature:	-25 to +55°C
Storage temperature:	-40 to +70°C
Relative humidity:	90% at 20°C.
Weight :	70/100v line: 2.60kg Low impedance: 2.20kg

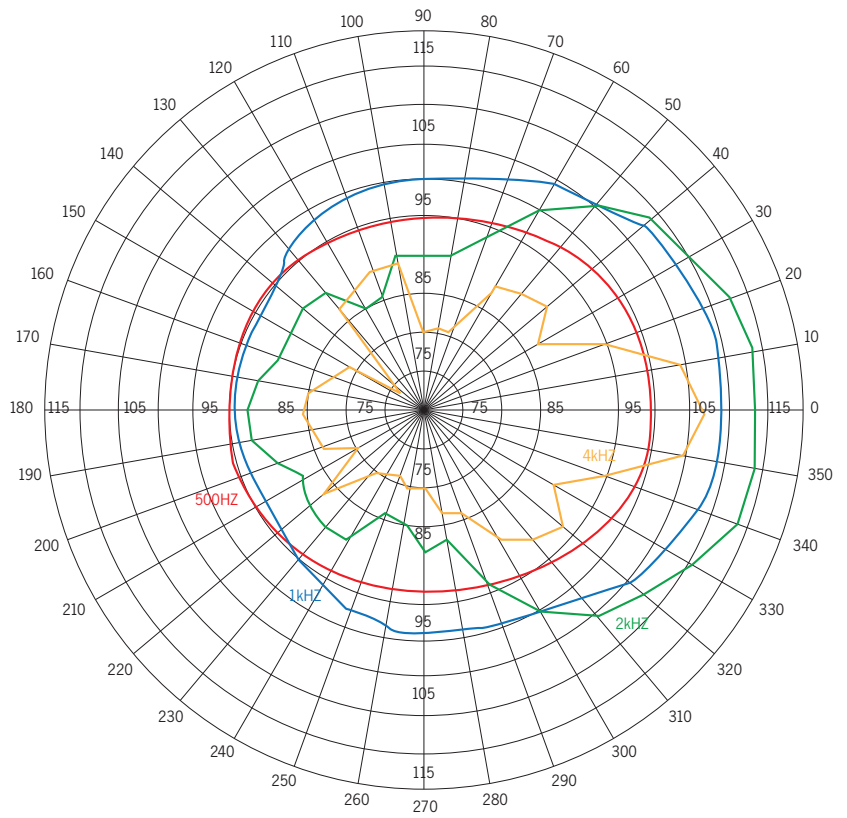

*SPL data +/-3dB(A). Measured at optimum voltage.

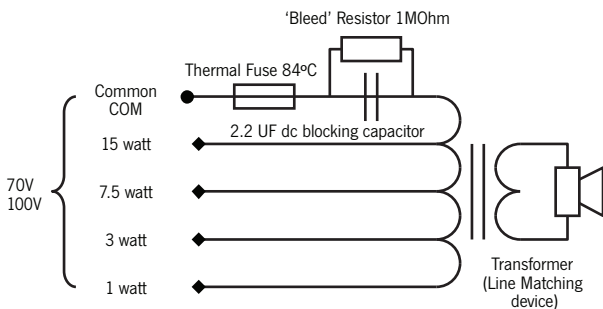

ML 15 & ML25 - 15 & 25 Watt Marine grade IP66 & IP67 Loudspeakers

ML158R, ML1516R & ML258R, ML2516R - 8 Ohm & 16 Ohm Low Impedance versions.

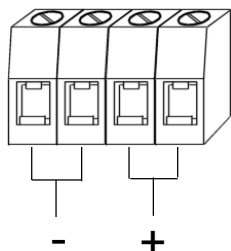

ML15 :	Input : 8 Ohm	Power : 15Watts	I/P Volts : 10.95V	
	Input : 16 Ohm	Power : 15Watts	I/P Volts : 15.49V	
	ML25 :	Input : 8 Ohm	Power : 25Watts	I/P Volts : 14.14V
		Input : 16 Ohm	Power : 25Watts	I/P Volts : 20.00V



ML 15



ML 25

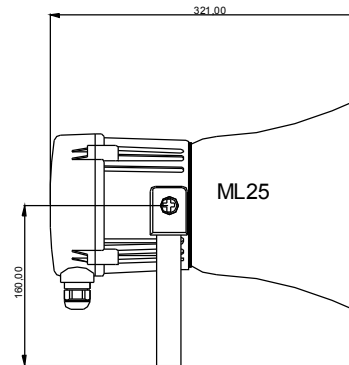
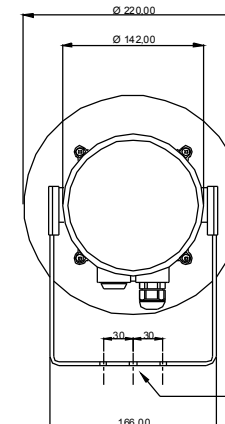
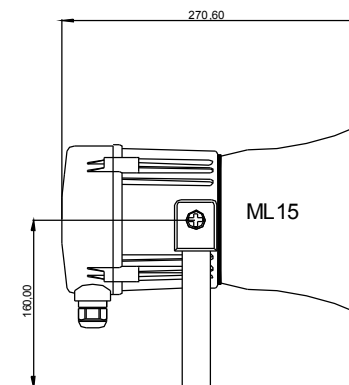
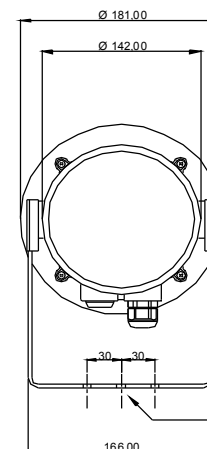

- End of line monitoring resistor can be connected across the terminals on the end of line unit. If it is fitted, cut the LINK on the PCB of all loudspeakers to ensure DC blocking capacitor is in circuit. Ensure polarity of monitoring voltage is correct.
- Une résistance de contrôle de fin de ligne peut être reliée entre les bornes de l'appareil de fin de ligne. Si une LIAISON est montée, la couper sur la carte de circuits imprimés de chaque haut-parleur pour assurer que le condensateur de blocage c.c. est en circuit. S'assurer que la polarité de tension de contrôle est correcte.
- Der Widerstand am Ende der Überwachungsleitung kann zwischen den Klemmen am letzten Gerät in der Kette angeschlossen werden. Wenn er angebracht ist, das Verbindungsglied auf den Leiterplatten aller Lautsprecher durchtrennen, um sicherzustellen, dass der Gleichspannungs-Sperrkondensator im Stromkreis ist. Sicherstellen, dass die Polarität der Überwachungsspannung richtig ist.
- Il resistore di controllo di fine linea può essere collegato tra i morsetti sull'unità di fine linea. In tal caso, interrompere sul circuito stampato il COLLEGAMENTO di tutti gli altoparlanti per fare in modo che il condensatore di blocco in CC sia inserito nel circuito. Verificare che la polarità della tensione di monitoraggio sia corretta.
- La resistencia de monitorización de extremo de la línea puede conectarse a través de los terminales de la unidad situados en el extremo de línea. Si está instalada, corte la conexión de la PCB de todos los altavoces para asegurarse de que el condensador de bloqueo de CC está conectado al circuito. Compruebe que la polaridad de la tensión de monitorización es correcta.
- Entre os terminais da unidade de fim de linha pode-se ligar uma resistência de monitorização de fim de linha. Se esta estiver montada, corte o fio de LIGAÇÃO no circuito impresso de todos os altifalantes para garantir que o condensador de bloqueio de cc fica inserido no circuito. Certifique-se de que a polaridade da tensão de monitorização está correcta.
- Der kan sluttes en EOL-modstand til den sidste enhed i rækken. Hvis en sådan tilsluttes, skal forbindelsen til højttalerne på printkortet afbrydes for at sikre, at jævnstrømsspærningen er aktiv. Sørg for, at spændingspolariteten er korrekt.
- De controleweerstand aan het einde van de lijn kan worden aangesloten op de klemmen van het eindapparaat. Als dit aangebracht is moet de verbinding op de PCB van alle luidsprekers worden verbroken om ervoor te zorgen dat de spercondensator in circuit is. Zorg ervoor dat de polariteit van de controlespanning correct is.
- end of line overvåkingsresistor kan koples på tvers av terminalene i den siste enheten i linken. Hvis denne monteres, kutt linken på kretskortet til samtlige høyttalere for å sikre at den forhåndsmonterte elektrolyttkondensatoren blir aktivert. Sørg for at polariteten til overvåkingspenning er korrekt.
- Ett slutn ostånd kan kopplas till anslutningsplintarna på ledningsslutsenheten. Om så görs, koppla ur stiften på alla högtalares kretskort för att kontrollera att spärrkondensatorn för likspänning är inkopplad. Kontrollera att polariteten på kontrollspänningen är korrekt.

ML15100V - 100V Line version.

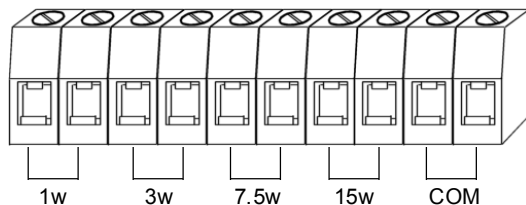

- End of line monitoring resistor can be connected across the terminals on the end of line unit.
- Une résistance de contrôle de fin de ligne peut être reliée entre les bornes de l'appareil de fin de ligne.
- Der Widerstand am Ende der Überwachungsleitung kann zwischen den Klemmen am letzten Gerät in der Kette angeschlossen werden.
- Il resistore di controllo di fine linea può essere collegato tra i morsetti sull'unità di fine linea.
- La resistencia de monitorización de extremo de la línea puede conectarse a través de los terminales de la unidad situados en el extremo de línea.
- Entre os terminais da unidade de fim de linha pode-se ligar uma resistência de monitorização de fim de linha.
- Der kan sluttes en EOL-modstand til den sidste enhed i rækken.
- De controleweerstand aan het einde van de lijn kan worden aangesloten op de klemmen van het eindapparaat.
- end of line overvåkingsresistor kan koples på tvers av terminalene i den siste enheten i linken.
- Ett slutm otstånd kan kopplas till anslutningsplintarna på ledningssslutsenheten.

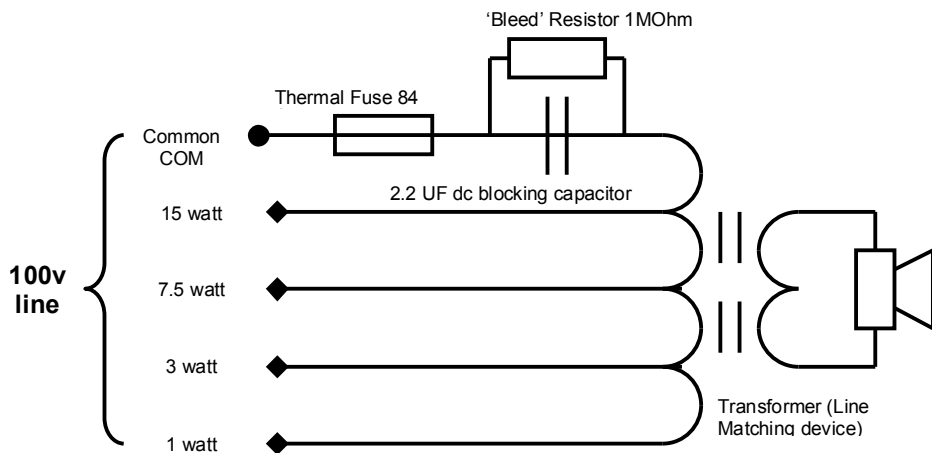

ML25100V - 100V Line version.

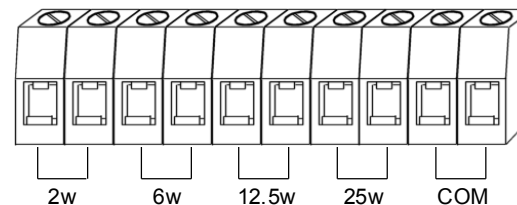

- End of line monitoring resistor can be connected across the terminals on the end of line unit.
- Une résistance de contrôle de fin de ligne peut être reliée entre les bornes de l'appareil de fin de ligne.
- Der Widerstand am Ende der Überwachungsleitung kann zwischen den Klemmen am letzten Gerät in der Kette angeschlossen werden.
- Il resistore di controllo di fine linea può essere collegato tra i morsetti sull'unità di fine linea.
- La resistencia de monitorización de extremo de la línea puede conectarse a través de los terminales de la unidad situados en el extremo de línea.
- Entre os terminais da unidade de fim de linha pode-se ligar uma resistência de monitorização de fim de linha.
- Der kan sluttes en EOL-modstand til den sidste enhed i rækken.
- De controleweerstand aan het einde van de lijn kan worden aangesloten op de klemmen van het eindapparaat.
- end of line overvåkingsresistor kan koples på tvers av terminalene i den siste enheten i linken.
- Ett slutm otstånd kan kopplas till anslutningsplintarna på ledningssslutsenheten.

