

BExBGL1 L.E.D. Beacon

The flameproof BExBGL1 L.E.D. beacon is suitable for Zone 1, 2, 21 & 22 applications.

With an array of 32 high output L.E.D.s the BExBGL1 unit is a multi-functional beacon suitable for all signalling applications. The robust construction makes installation in the harshest of environments possible. Additional features include UV stable prismatic lens, stainless steel guard and mounting bracket as standard. Multi-function: The BExBGL1 features a total of 9 modes of operation: 4 rotating effect modes, 4 flashing modes and a steady mode for use in indicator / status applications. Based on the mode selected the user can also select two alternative L.E.D. modes remotely.

The BEx range features enclosures manufactured from corrosion proof, marine grade copper free LM6 aluminium which is phosphated and powder coated. All models have two M20 cable entries, large termination areas and an ingress protection of IP66/67.

Features:

- Glass dome with optically enhanced prismatic PC lens
- Stainless Steel guard
- Very large termination area.
- Ratchet adjustable stainless steel 'U' bracket.

Approvals:

- ATEX certificate: KEMA 00ATEX2006, EN 60079-0 : 2006, EN 60079-1 : 2007, EN 61241-0 : 2006, EN 61241-1 : 2004
- IECEx certificate: IECEx KEM 10.0002, IEC 60079-0 : 2004 (Ed4), IEC 60079-1 : 2007 (Ed6), IEC 61241-0 : 2004 (Ed1), IEC 61241-1 : 2004 (Ed1)
- GOST-R certificate: POCC GB.JB05.B02205
- Safety-integrity suitability: SIL1
- Inmetro certificate: 10-IEEx-0010

Part codes:

Part Code:

BExBGL1D**

Classification:

ATEX/IECEX:
 II 2G Ex d IIC T4 Ta. -50° to +70°C
 II 2G Ex d IIC T5 Ta. -50° to +40°C
 II 2D Ex tD A21 IP67 T120 Ta. +70°C
 based on max. Ta. 70°C

GOST-R:

1ExdIICT5 Ta. -50° to +55°C
 1ExdIICT4 Ta. -50° to +40°C
 DIP A21 Ta T4

** = Voltage & lens colour reference:

Voltage options: 24DC (10-50V dc),
115AC, 230AC, 24AC

Lens colour options: -AM (Amber)
-BL (Blue)
-GN (Green)
-RD (Red)
-YW (Yellow)

e.g: BExBGL1D230AC-AM

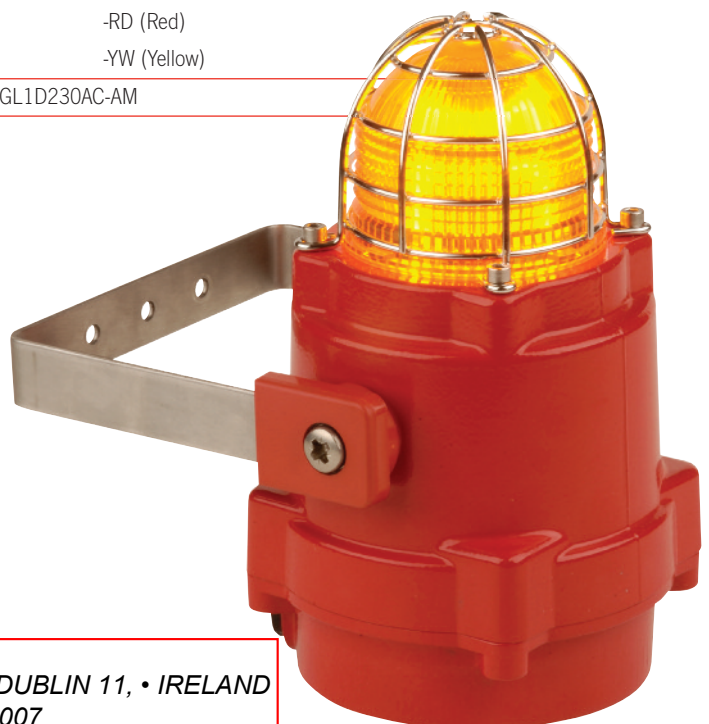

COMSEC PROTECTION SYSTEMS LTD.

UNIT 26, STADIUM BUSINESS PARK, • BALLYCOOLIN ROAD, • DUBLIN 11, • IRELAND

PHONE: +353 (0)1 8853008 • FAX: +353 (0)1 8853007

EMAIL: info@comsec.ie • WEB: <http://www.comsec.ie>

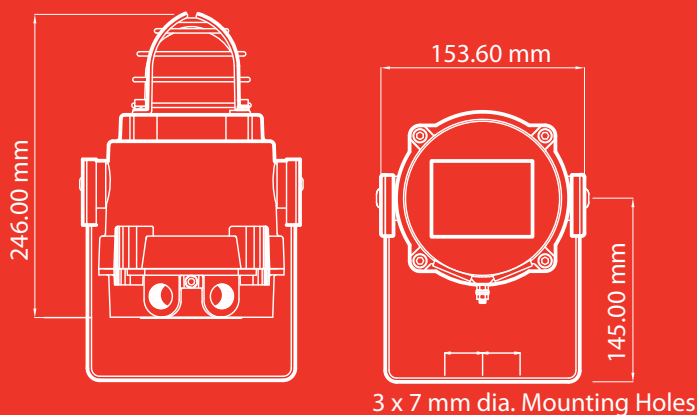
**Specification:**

Light source:	Array of 32 high output L.E.D.s
Effective Candela:	11 cd*
Lens colours:	Amber, Blue, Green, Red & Yellow
Voltages DC:	10-50V dc
Voltages AC:	24V ac; 115V ac; 230V ac
Ingress protection:	IP66/67
Housing material:	Marine grade copper free LM6 Aluminium
Housing finish:	Phosphated & powder coated finish - anti-corrosion.
Colour:	RAL3000 Red (others available on request)
Cable entries:	Dual M20 ISO (one stopping plug included)
Terminals:	0.5 to 4.0mm ² cables.
Line monitoring :	Min. 500 Ohm 2w, or 3k3 Ohm 0.5w res. or diode (dc versions).
Weight :	DC:2.45kg AC: 2.75kg

Current consumption:

Version:	Voltage range:	Current:
24V dc	10-50V dc	400mA
48V dc	10-50V dc	230mA
24V ac	50Hz/60Hz +/-10%	812mA
115V ac	50Hz/60Hz +/-10%	140mA
230V ac	50Hz/60Hz +/-10%	70mA

Multi-function patterns:

Mode:	Stage 1: [Selectable on board]	Stage 2: [Remotely selectable]	Stage 3: [Remotely selectable]
1	All L.E.D's on	Alternate Side Flash 1:1 2Hz	Double Strike Flash 2Hz
2	Rotating: Fast 1	Rotating: Fast 2	All L.E.D's on
3	Rotating: Fast 2	Double Strike Flash 2Hz	All L.E.D's on
4	Rotating: Slow 1	Alternate Side Flash 1:1 2Hz	All L.E.D's on
5	Rotating: Slow 2	Double Strike Flash 1Hz	All L.E.D's on
6	Double Strike Flash 1Hz	Alternate Side Flash 1:1 2Hz	All L.E.D's on
7	Single Strike Flash 2Hz	Rotating: Fast 2	All L.E.D's on
8	Double Strike Flash 2Hz	Rotating: Fast 2	All L.E.D's on
9	Alternate Side Flash 1:1 2Hz	Rotating: Fast 2	All L.E.D's on

Assemblies:

The products from the BEx range are available as multiple unit assemblies with and without junction boxes. See the BExP data sheet for further info.



*All candela data is representative of performance with red lens at optimum voltage.

1) Introduction

The BExBGL1D is a flameproof LED beacon which is certified to meet the ATEX directive 94/9/EC and the IECEx scheme. The beacon produces visual warning signals and can be used in hazardous areas where potentially flammable gas and dust atmospheres may be present. The BExBGL1D LED beacon has nine different flash patterns including a steady ON state and can also be remotely switched to a second and third flash pattern. The beacon can be used in Zone 1 and Zone 2 areas with gases in groups IIA, IIB and IIC and Temperature Classifications of T1, T2, T3, and T4. It can also be used in a temperature classification T5, if the upper ambient temperature is restricted to +40°C. The unit can be used in Zone 21 and Zone 22 areas for combustible dusts and has an IP rating of IP 67 and a surface temperature rating of T120°C or T105°C if the upper ambient temperature is restricted to +55°C and T95°C if the upper ambient temperature is restricted to +40°C.

2) Marking

All units have a rating label, which carries the following important information:-

Unit Type No. BExBGL1D

Input Voltage: DC Units 10-50V
AC Units 10-35V or 230V or 115V

Codes: Ex d IIC T4 for Ta -50°C to +70°C
Ex d IIC T5 for Ta -50°C to +40°C
Ex tD A21 T120°C based on max. Ta of +70°C

Certificate No's KEMA 00ATEX2006
IECEx KEM 10.0002

Epsilon x Equipment Group and Category:  II 2G/D

CE Marking Notified Body No.  0518

Warnings: DO NOT OPEN WHEN AN EXPLOSIVE GAS OR DUST ATMOSPHERE IS PRESENT

COVER BOLTS CLASS A4-80

USE HEAT RESISTING CABLES AND CABLE GLANDS (Rated 110°C) AT AMB. TEMPERATURES OVER 40°C

Year of Construction / Serial No. i.e. 10 / 1DB73000001

3) Type Approval Standards

The beacon has EC Type Examination and IECEx certificates issued by KEMA and have been approved to the following standards:-

EN60079-0:2006 IEC60079-0:2004 (Ed4) General Requirements
EN60079-1:2007 IEC60079-1:2007 (Ed6) Flameproof Enclosure 'd'

EN61241-0:2006 IEC61241-0:2004 (Ed1) Dust General Requirements
EN61241-1:2004 IEC60079-1:2004 (Ed1) Dust Enclosures tD

4) Installation Requirements

The led beacons must be installed in accordance with the latest issues of the relevant parts of the BS EN 60079 specifications or the equivalent IEC specifications – Selection, Installation and maintenance of electrical apparatus for use in potentially explosive atmospheres (other than mining applications or explosive processing and manufacture):-

EN60079-14:2008 IEC60079-14:2007 (Ed4) Electrical Installations in Hazardous Areas (other than mines)

EN60079-10:2003 IEC60079-10:2008 (Ed1) Classification of Hazardous Areas

The installation of the units must also be in accordance with any local codes that may apply and should only be carried out by a competent electrical engineer who has the necessary training.

5) Zones, Gas Group, Category, IP Rating and Temperature Classification

The BExBGL1D beacons have been certified Ex d IIC T4 for Ta -50°C to +70°C and Ex d IIC T5 for Ta -50°C to +40°C for gas and IP67 T120°C Ta ≤ +70°C, T105°C Ta ≤ +55°C and T95°C Ta ≤ +40°C for dust. This means that the units can be installed in locations with the following conditions:-

Area Classification Gas:

Zone 1	Explosive gas air mixture likely to occur in normal operation.
Zone 2	Explosive gas air mixture not likely to occur, and if it does, it will only exist for a short time.

Gas Groupings:

Group IIA	Propane
Group IIB	Ethylene
Group IIC	Hydrogen and Acetylene

Temperature Classification:

T1	400° C	
T2	300° C	
T3	200° C	
T4	135° C	
T5	100° C	Amb. +40°C

Area Classification Dust:

Zone 21	Explosive dust air mixture likely to occur in normal operation.
Zone 22	Explosive dust air mixture not likely to occur, and if it does, it will only exist for a short time.

IP Rating: IP67 T120°C Ta ≤ +70°C
 T105°C Ta ≤ +55°C
 T95°C Ta ≤ +40°C

Equipment Category: 2G/D

Ambient Temperature Range: -50°C to +70°C
 (T5 = +40°C)

6) Beacon Location and Mounting

The location of the beacons should be made with due regard to the area over which the warning signal must be visible. They should only be fixed to services that can carry the weight of the unit.

The beacons should be securely bolted to a suitable surface using the 7mm diameter boltholes in the stainless steel U shaped mounting bracket (see figure 1). The required angle can be achieved by loosening the two large bracket screws in the side of the unit, which allow adjustment of the beacon in steps of 18°. On completion of the installation the two large bracket adjustment screws on the side of the unit must be fully tightened to ensure that the unit cannot move in service.

SAFETY WARNING:

The flashdome guard must not be removed from the unit at any time.

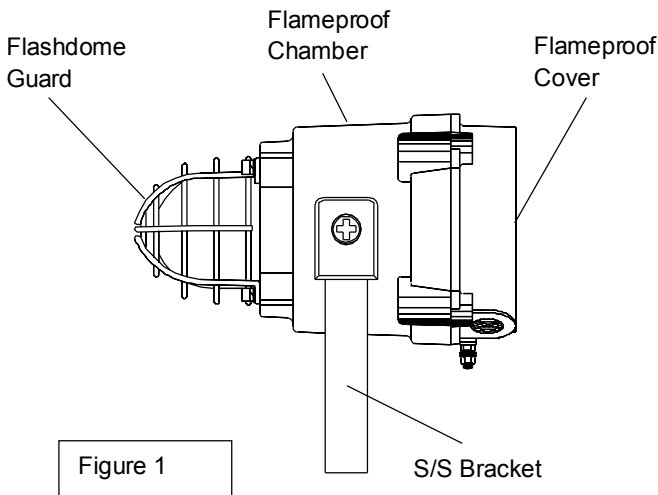

Figure 1

7) Access to the Flameproof Enclosure

In order to connect the electrical supply cables to the beacon it is necessary to remove the flameproof cover to gain access to the flameproof chamber. To achieve this remove the four M6 hexagon socket head screws (see figure 2) and withdraw the flameproof cover taking extreme care not to damage the flameproof joints in the process.

Note the four **M6 screws are Class A4-80 stainless steel and only screws of this category can be used on the beacons.** It is therefore important that these screws and their spring washers are kept in a safe place during installation.

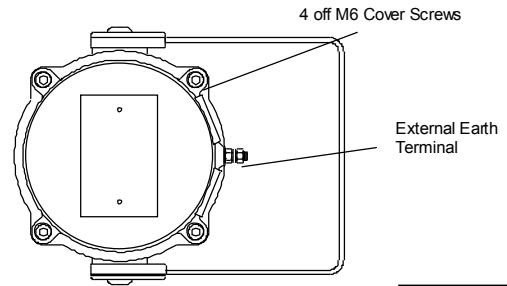

Figure 2

On completion of the cable wiring installation the flameproof joints should be inspected to ensure that they are clean and that they have not been damaged during installation. Also check that the earth bonding wire between the two casting sections is secure and the 'O' ring seal is in place. When replacing the flameproof cover casting ensure that it is square with the flameproof chamber casting before inserting. Carefully push the cover in place allowing time for the air to be expelled. Only after the cover is fully in place should the four M6 Stainless Steel A4-80 cover bolts and their spring washer be inserted and tightened down. If the cover jams while it is being inserted, carefully remove it and try again. Never use the cover bolts to force the cover into position.

8) Power Supply Selection

It is important that a suitable power supply is used to run the beacons. The power supply selected must have the necessary capacity to provide the input current to all of the beacons

The following table shows the input current taken by the various beacons:-

Unit Type	Nominal I/P Voltage	Input Current	Max. I/P
BExBGL1D	10-50V DC	400mA@24V	50V
BExBGL1D	10-35V AC	812mA@20V	35V
BExBGL1D	230V AC	65mA	253V
BExBGL1D	115V AC	135mA	126V

The input current will vary according to the voltage input level. The current levels shown above are for nominal input voltage.

The above table also shows the maximum voltages at which the beacons can be operated.

9) Cable Selection

When selecting the cable size consideration must be given to the input current that each unit draws (see table above), the number of beacons on the line and the length of the cable runs. The cable size selected must have the necessary capacity to provide the input current to all of the beacons connected to the line.

SAFETY WARNING: If the BExBGL1D beacons are used at high ambient temperatures, i.e. over +40°C, then the cable entry temperature may exceed +70°C and therefore suitable heat resisting cables must be used, with a rated service temperature of at least 110°C.

10) Earthing

Both AC and DC beacon units must be connected to a good quality earth. The units are provided with internal and external earthing terminals which are both located on the terminal chamber section of the unit (see figures 2 and 3).

BExBGL1D Beacon Cover Internal View

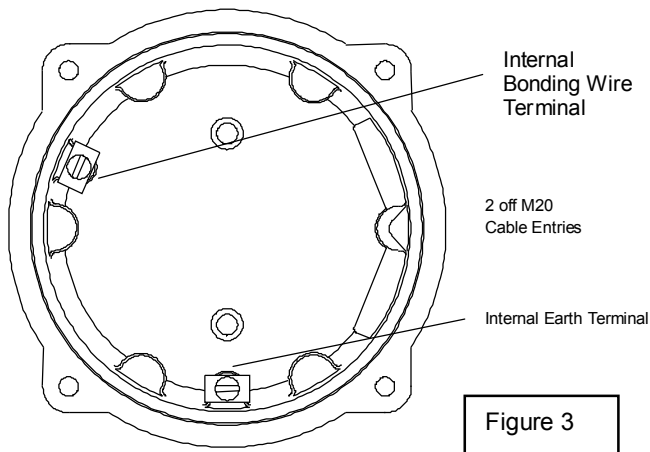

When using the internal earth terminal ensure that the stainless steel M4 flat washer is between the incoming earth wire and the enclosure.

When using the external earth terminal a cable crimp lug must be used. The cable lug should be located between the two M5 stainless steel flat washers. The M5 stainless steel spring washer must be fixed between the outer flat washer and the M5 stainless steel nut to ensure that the cable lug is secured against loosening and twisting.

The internal earth bonding wire ensures that a good quality earth is maintained between the flameproof chamber casting and the flameproof cover casting.

11) Cable Glands

The BExBGL1D beacons have dual cable gland entries which have an M20 x 1.5 entry thread as standard. Only cable glands approved for Ex 'd' applications can be used, which must be suitable for the type of cable being used and also meet the requirements of the Ex 'd' flameproof installation standard EN60079-14:2008 / IEC60079-14:2007.

When only one cable entry is used the other one must be closed with an Ex 'd' flameproof blanking plug, which must be suitably approved for the installation requirements.

For combustible dust applications, the cable entry device and blanking elements shall be in type of explosion protection increased safety "e" or flameproof enclosure "d" and shall have an IP 6X rating according to EN 60529.

SAFETY WARNING: If the BExBGL1D beacons are used at high ambient temperatures, i.e. over +40°C, then the cable entry temperature may exceed +70°C and therefore suitable heat resisting cable glands must be used, with a rated service temperature of at least 110°C.

12) Cable Connections

The cable supply connections are made into the terminal blocks on the electronic pcb assembly located in the flameproof enclosure, see section 7 of this manual for access to the flameproof enclosure. The AC unit has two live terminals and two neutral terminals for the input and output supply wiring and the DC unit has two +ve terminals and two -ve terminals for the input and output supply wiring. Both units have S2 and S3 terminals to remotely change the flash pattern, see section 13 of this manual.

BExBGL1D AC LED Beacons

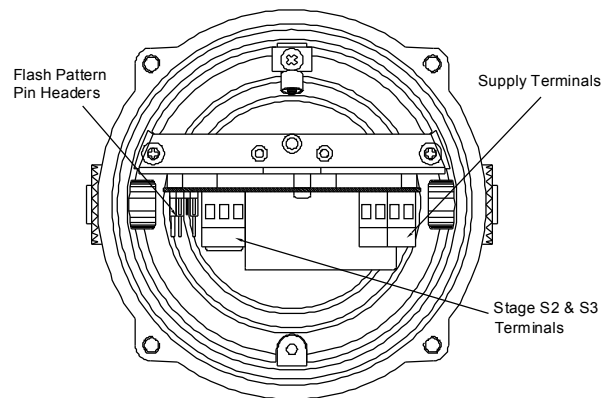

BExBGL1D DC LED Beacons

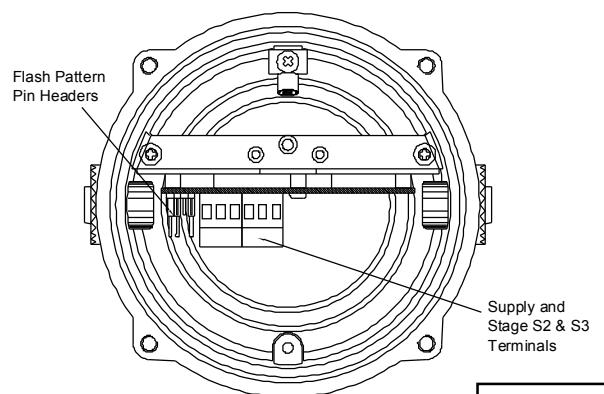

Wires having a cross sectional area of up to 2.5mm² can be connected to each terminal way. If an input and output wire is required a 2.5mm² wire can be connected to each terminal way. When connecting wires to the terminals great care should be taken to dress the wires so that when the cover is

inserted into the chamber the wires do not exert excess pressure on the terminal blocks. This is particularly important when using cables with large cross sectional areas such as 2.5mm².

13) Flash Pattern Selection and 2nd & 3rd Stages

The BExBGL1D LED beacons have 9 different flash patterns including one ON state that can be selected for the first stage. They can then be remotely switched to second and third stage flash patterns. The flash patterns are selected by pin headers on the pcb for both DC and AC units. The table on page four shows the pin header positions for the nine flash patterns and which patterns are available for the second and third stages. To operate the led beacon on stage one simply connect the supply voltage to the normal supply terminals (+ve and -ve for DC units, L and N for AC units).

The operation of the second and third stages is different for DC and AC units.

DC Units Second and Third Stage Selection

To change to the second stage flash pattern, simply connect a -ve supply line to terminal S2, while maintaining the dc supply to the +ve and -ve terminals. Similarly for the third stage flash pattern, connect a -ve supply line to terminal S3. The supply line to the S3 terminal will automatically override a supply to the S2 terminal.

AC Units Second and Third Stage Selection

To select the second and third stage flash patterns on the BExBGL1D AC beacons the Common (C) terminal on the three way terminal block on the pcb is connected to the S2 terminal for the second stage tone and the S3 terminal for the third stage tone.

14) End of Line Monitoring (DC Units)

On the BExBGL1D DC beacons, dc reverse line monitoring can be used if required. All DC beacons have a blocking diode fitted in their supply input lines. An end of line monitoring diode or an end of line monitoring resistor can be connected across the +ve and -ve terminals. If an end of line resistor is used it must have a minimum resistance value of 3k3 ohms and a minimum wattage of 0.5 watts or a minimum resistance value of 500 ohms and a minimum wattage of 2 watts.

Flash Pattern Table

Stage 1 Pattern	LED Flash Pattern	Stage 2 Pattern	Stage 3 Pattern
1	ON	9	8
2	Rotating 3 LED on Fast	7	1
3	Rotating 6 LED on Fast	8	1
4	Rotating 3 LED on Slow	9	1
5	Rotating 6 LED on Slow	6	1
6	Double strike strobe 1 Hz	9	1
7	Single strike strobe 2 Hz	3	1
8	Double strike strobe 2 Hz	3	1
9	Alternate side flash 1:1 2 Hz	3	1

PIN HEADER POSITIONS

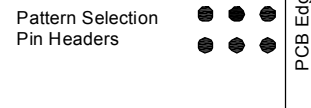
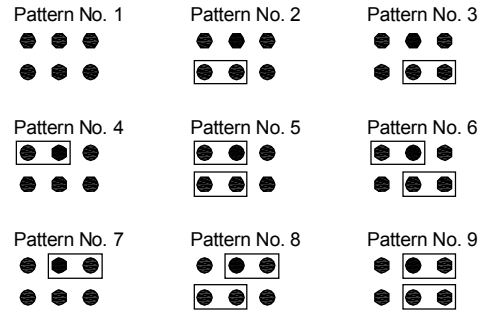

BExBGL1D DC LED Beacon Wiring

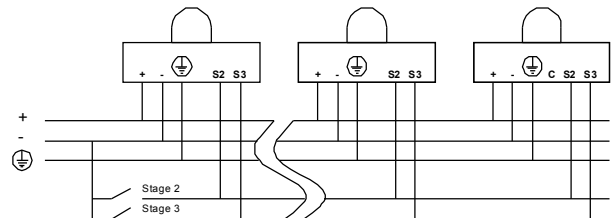

BExBGL1D AC LED Beacon Wiring

