

MON100

Ziton NLM Network Monitor

A network monitoring, maintenance and commissioning tool



Overview

The MON100, a NLM network monitor, was developed in collaboration with the Ziton engineers as a tool that could be used for stability monitoring and network fault diagnosis.

The tool delivers new advantages to the industry by improving efficiency through rapid fault diagnosis and promoting new revenue returns using the MON100 maintenance support option.

It provides the insight required to rapidly identify and log relevant weaknesses in the physical network layer of a RS485 system.

The MON100 can be used with the MONTAP graphical software application which supports the generation of detailed reports. These reports present the 20 most recent network recovery events.

The system reports can be used to track changes to the network configuration and identify signal degradation.

This information is also useful for improved preventative maintenance planning.

Features

- Network configuration monitoring with indications for double addressing, NLM firmware versions, incorrectly set or faulty switch settings, network interference and isolated fire panels
- Network system stability monitoring with optional data logging
- Reports generation with event tracking for maintenance and commissioning sign-off
- Time stamped records for fault analysis support
- Supports rapid fault location and diagnosis with MONTAP, the graphical software application
- Dynamic network monitoring using the MONTAP application
- Monitors the network signal amplitude to determine the need for boosters
- 2.5kV isolation between external connection and monitored network
- No additional network interference through impedance loading with MON100
- "Listen only" mode to protect the monitored network
- Supports remote and local system monitoring
- Data extraction or dynamic monitoring via RS232, RS485, USB, Bluetooth or WIFI
- Non-volatile memory retains the 20 most recent network events
- Node power loss and watchdog resets are recorded in events
- Assists in identifying ZP3 network cards presenting intermittent faults
- DIN Rail mounting
- Supports networks at 9600-115kbits/sec
- Site, User and Unit Identity tracking for maintenance



Instance
Managing Data Xchange

Specifications

Dimension Diagram

Dimensions: 70 X 58 X 86 mm
Weight: 0.2kg

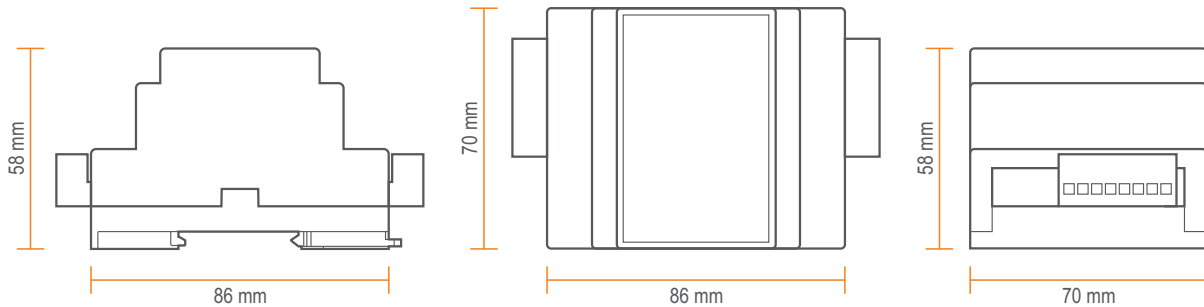

Power

Operating voltage: 18 to 36V (24V DC nominal)
Rated current: 250mA (at 24V)

Interfaces

RS485: Port A: Fixed Termination
Port B: Dynamic Termination
Port C: Dynamic Termination
Port B & Port C: Isolated (2.5kV)
Baud Rate: 9600 to 115200 (selectable / configurable)
USB: USB Micro-B connection (Device / Slave Mode)

Temperature

Operating: -10 to 70°C
Storage: -40 to 70°C

Agency Approvals and Standards

CE, RoHs, WEEE compliant
EMC EN 61000-6-2, Immunity Standard (Industrial Environments)
EN 61000-6-4, Emission Standard (Industrial Environments)
Safety EN 60950, IT Equipment



Instance
Managing Data Xchange

COMSEC PROTECTION SYSTEMS LTD.

UNIT 26, STADIUM BUSINESS PARK, • BALLYCOOLIN ROAD, • DUBLIN 11

PHONE: (01) 8853008 • FAX: (01) 8853007

EMAIL: info@comsec.ie • WEB: http://www.comsec.ie