

STOPPER

HAS THE STOPPER CUT FALSE ALARMS?

We had an intermittent problem with pupils activating the break glass call points in our automatic fire systems. Each alarm led to attendance by the local fire brigade but also led to considerable inconvenience, as all of the buildings in the school complex had to be evacuated every time an alarm was given. Since Derbyshire County Council Technical Services Department installed the Stoppers, not a single false fire alarm has been recorded.

Sue Kettle – Buxton Community School



FEATURES

- Constructed from tough clear polycarbonate
- Protects equipment from accidental operation, vandalism, product misuse, dust and weather
- Available with or without integral sounder.
- Integral sounder powered by a 9V PP3 battery (included)
- Optional 12 or 24 VDC powered units
- Available for flush or surface mounted products
- Lock or break seal options for added security
- Optional depth spacers to accommodate a wider variety of products
- Cover backed by a lifetime guarantee against breakage in normal use
- Polycarbonate tested -40°F (-40°C) to 120°F (49°C)
- Easy to install, can retrofit over existing device

▼ Stopper dimensions and technical information (STI 6530, STI 6531, STI 6532 & STI 6533)

STI STOPPER

Protective cover to help stop malicious or accidental false fire alarms. This unique device has been helping stop false fire alarms around the world for decades, without restricting legitimate operation of devices such as fire alarm break glass call points. Ideal for schools, colleges, hospitals, nursing homes, hotels and all public buildings where there is a history or a threat of false fire alarms.

HOW IT WORKS

The Stopper consists of a clear, tamper-proof, tough polycarbonate cover and frame that retrofits over the break glass call point. When lifted to gain access to the break glass, its optional battery powered integral sounder emits a piercing 96dB (at 1 metre). Immediate attention is drawn to the area and a prankster will either run or be caught.

MODELS AVAILABLE

- STI 6530** Stopper flush mounted without integral sounder
- STI 6531** Stopper surface mounted without integral sounder (includes 30mm spacer)
- STI 6532** Stopper flush mounted with integral sounder
- STI 6533** Stopper surface mounted with integral sounder (includes 30mm spacer)

ACCESSORIES

- STI 6503** 30mm spacer (supplied with STI 6531 & STI 6533)
- STI 6504** 50mm spacer
- STI C024** Backplate (for irregular surfaces)
- STI/BS** Breakable seals (pack of 10)
- E009** Deactivation pin

OPTIONS

COLOURS AVAILABLE For Green, Blue or Yellow add /G/B or /Y

ADDITIONAL SECURITY For break seal add /BS. For lock add /L

EXAMPLE STI 6533/G/BS = Green Stopper, surface mounted with sounder and break seal facility
STI 6530/BS = Red Stopper, flush mounted without sounder but with break seal facility

NB: The Stopper is supplied in red and with the operating instructions IN CASE OF FIRE – LIFT COVER BREAK GLASS
Alternative and custom markings are available

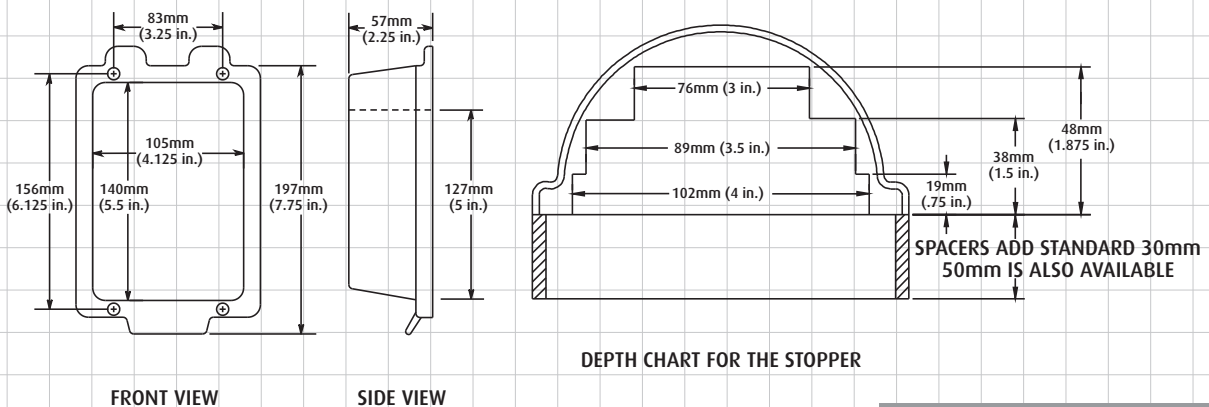

(SAMPLE SUBJECT TO AVAILABILITY)

Do you need to protect an external call point or switch from the elements?
See our Weather Stopper on page 6