

PH450

Electro-magnetic door handle, 400mm long



Short door handle incorporating one slim maglock. Provides a sturdy modern design handle with concealed maglock, ideal for office environments.

Features

- Fail safe operation (power to lock)
- Dual voltage 12Vdc or 24Vdc (selectable)
- Modern design
- Satin anodised aluminium finish
- Concealed wiring
- Lock monitoring
- Armature fitted inside the housing approving appearance
- Integrated magnet and armature plate included

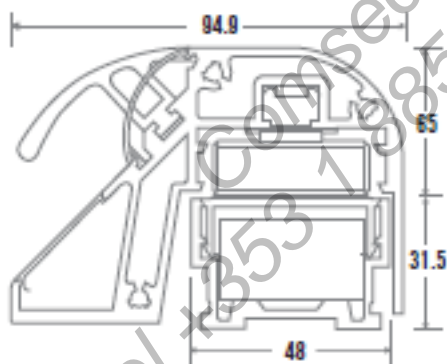

Technical Information

- Up to 275kg (600lb) holding force
- Length: 400mm
- Total current draw:
 - 500mA @ 12Vdc
 - 250mA @ 24Vdc
- Monitoring relay:
 - COM/NO/NC
 - (1A @ 24Vdc)

Related Products

PSU3A-12(B)



DG500



SPB003S



CP3-LSRC

