

# E2xCS112-5

## Combined Alarm Sounder and Xenon Strobe Beacon

**The hazardous area E2xCS112-5 combined alarm sounder and Xenon strobe beacon is ATEX certified for Zone 2 applications and also UL approved for Class I Div 2 applications.**

The E2xCS112-5 combines a 116dB(A) alarm sounder with a 5 Joule Xenon strobe beacon providing a complete audio-visual signalling solution whilst reducing the installation time and costs associated with multiple unit installations.

The E2x range features enclosures manufactured from lightweight, corrosion proof PPS and high impact, fire retardant ABS re-entrant flare horns; both of which are suitable for the harshest of environments.

### Features:

- Very large termination area.
- Ratchet adjustable stainless steel 'U' bracket.
- Stainless Steel dome guard as standard
- Xenon tube mechanically secured against vibration/shock.
- User replaceable Xenon tube assembly.
- Automatic synchronisation on multi-sounder system.

### Approvals:

- ATEX certificate: DEMKO 06 ATEX 0421554, EN 50021: 1999
- UL File ref: E230764

### Part codes:

| Part Code:           | Classification:                                   |
|----------------------|---|
| <b>ATEX version:</b> |   |
| E2xCS1125EG**        | II 3G EEx nA nL IIC T2 (Tamb -20°C to +55°C)      |
|                      | II 3G EEx nA nL IIC T3 (Tamb -20°C to +40°C)      |
| <b>UL version:</b>   |   |
| E2xCS1125UL**        | Class I, Div 2, Grps A,B,C,D T2D (215°C) at +55°C |
|                      | Class I, Div 2, Grps A,B,C,D T3 (200°C) at +40°C  |
|                      | Class II, Div 2, Grps F & G T6 (85°C) at +40°C    |
|                      | Class III, Div 1, T6 (85°C) at +40°C              |
|                      | Class III, Div 1, T5 (100°C) at +55°C             |

\*\* = Voltage & lens colour reference:

Voltage options: 12DC, 24DC, 48DC, 115AC, 230AC

Lens colour options: -AM (Amber)  
-BL (Blue)  
-CL (Clear)  
-GN (Green)  
-RD (Red)  
-YW (Yellow)

Replacement Xenon flash tube: FTASSYE2X

### Current consumption:

|                 | Alarm Sounder  |          | Xenon Beacon   |          |
|-----------------|----------------|----------|----------------|----------|
| Version:        | Voltage range: | Current: | Voltage range: | Current: |
| 24V dc          | 10-30V dc      | 284mA    | 20-28V dc      | 275mA    |
| 48V dc          | 38-58V dc      | 146mA    | 42-58V dc      | 145mA    |
| 115V ac 50/60Hz | +/-10%         | 104mA    | +/-10%         | 80mA     |
| 230V ac 50/60Hz | +/-10%         | 54mA     | +/-10%         | 30mA     |

### Effective Candela lens colour factor:

| Amber | Blue | Clear | Green | Red  | Yellow |
|-------|------|-------|-------|------|--------|
| 0.51  | 0.12 | 1.00  | 0.49  | 0.15 | 0.86   |



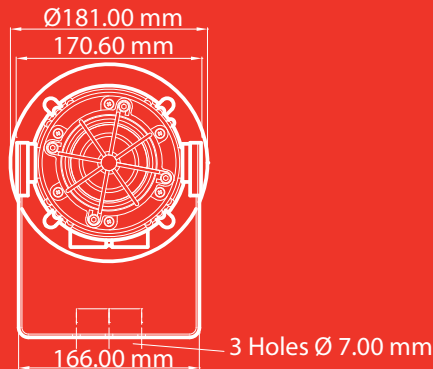
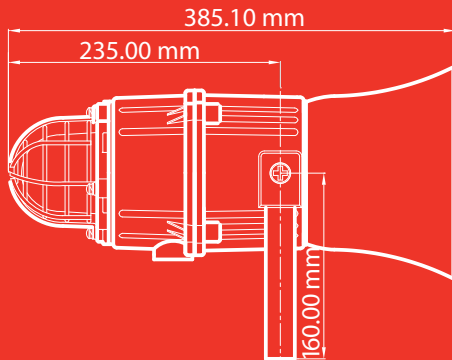

### Specification:

#### Alarm Sounder:

|                  |                                       |
|------------------|---------------------------------------|
| Maximum output:  | 116dB(A) @ 1 metre                    |
| Nominal output:  | 311xdB(A) @ 1m +/- 3dB - Tone 2       |
| No. of tones:    | 45 (UKOOA/PFEER compliant)            |
| No. of stages:   | 3                                     |
| Volume control:  | Max. 113dB(A); Min. 105dB(A) - Tone 2 |
| Effective range: | 100m @ 1KHz                           |

#### Beacon:

|                         |   |
|-------------------------|---|
| Energy:                 | 5 Joules (5Ws)                          |
| Flash rate:             | 1Hz (60 fpm)                            |
| Peak Candela:           | 31,950 cd                               |
| Effective Intensity cd: | 101 cd*                                 |
| Lens colours:           | Amber, Blue, Clear, Green, Red & Yellow |

#### General:

|                     |  |
|---------------------|--|
| Voltages DC:        | 24vdc; 48vdc   |
| Voltages AC:        | 115vac; 230vac   |
| Ingress protection: | ATEX: IP66 & IP67 UL: Type 4, 4X & 13                    |
| Housing material:   | UL94V0 PPS & ABS   |
| ATEX cable entries: | 2 x M20 ISO cable gland entries - with 1 blanking plug.  |
| UL cable entries:   | 1 x 1/2" NPT cable gland entry - with 0.5m flying leads. |
| Terminals (ATEX):   | 0.5 to 4.0mm <sup>2</sup> - In & Out                     |
| Weight :            | DC: 3.00Kg AC: 3.50kg                                    |

\*Candela measurements representative of performance with clear lens at optimum voltage. SPL readings are at nominal voltage, typically +/-3dB and are for indication purposes only. Where applicable, reduce outputs by 5dB when a 10-30vdc unit is supplied 12vdc.

### Stage1 Frequency Description

| Stage1  | Frequency Description                                  | dB @ 1m*      | Stage2  | Stage3  |
|---------|--|---------------|---------|---------|
| Tone 1  | 340 Hz Continuous                                      | 107dB(A) @ 1m | Tone 2  | Tone 5  |
| Tone 2  | 800/1000Hz @ 0.25 sec Alternating - BS5839 Alarm tone  | 113dB(A) @ 1m | Tone 17 | Tone 5  |
| Tone 3  | 500/1200Hz @ 0.3Hz 0.5 sec Slow Whoop - NEN 2575:2000  | 113dB(A) @ 1m | Tone 2  | Tone 5  |
| Tone 4  | 800/1000Hz @ 1Hz Sweeping                              | 113dB(A) @ 1m | Tone 6  | Tone 5  |
| Tone 5  | 2400Hz Continuous                                      | 116dB(A) @ 1m | Tone 3  | Tone 20 |
| Tone 6  | 2400/2900Hz @ 7Hz Sweeping                             | 114dB(A) @ 1m | Tone 7  | Tone 5  |
| Tone 7  | 2400/2900Hz @ 1Hz Sweeping                             | 114dB(A) @ 1m | Tone 10 | Tone 5  |
| Tone 8  | 500/1200/500Hz @ 0.3Hz Sweeping                        | 113dB(A) @ 1m | Tone 2  | Tone 5  |
| Tone 9  | 1200/500Hz @ 1Hz - DIN / PFEER P.T.A.P.                | 113dB(A) @ 1m | Tone 15 | Tone 2  |
| Tone 10 | 2400/2900Hz @ 2Hz Alternating                          | 116dB(A) @ 1m | Tone 7  | Tone 5  |
| Tone 11 | 1000Hz @ 1Hz Intermittent                              | 112dB(A) @ 1m | Tone 2  | Tone 5  |
| Tone 12 | 800/1000Hz @ 0.875Hz Alternating                       | 112dB(A) @ 1m | Tone 4  | Tone 5  |
| Tone 13 | 2400Hz @ 1Hz Intermittent                              | 116dB(A) @ 1m | Tone 15 | Tone 5  |
| Tone 14 | 800Hz 0.25sec on, 1 sec off Intermittent               | 113dB(A) @ 1m | Tone 4  | Tone 5  |
| Tone 15 | 800Hz Continuous                                       | 113dB(A) @ 1m | Tone 2  | Tone 5  |
| Tone 16 | 660Hz 150mS on, 150mS off Intermittent                 | 109dB(A) @ 1m | Tone 18 | Tone 5  |
| Tone 17 | 544Hz (100mS)/440Hz (400mS) - AFNOR NF S 32-001        | 109dB(A) @ 1m | Tone 2  | Tone 27 |
| Tone 18 | 660Hz 1.8sec on, 1.8sec off Intermittent               | 109dB(A) @ 1m | Tone 2  | Tone 5  |
| Tone 19 | 1.4KHz-1.6KHz 1s, 1.6KHz-1.4KHz 0.5s - AFNOR NFC48-265 | 114dB(A) @ 1m | Tone 2  | Tone 5  |
| Tone 20 | 660Hz Continuous                                       | 109dB(A) @ 1m | Tone 2  | Tone 5  |
| Tone 21 | 554Hz/440Hz @ 1Hz Alternating                          | 109dB(A) @ 1m | Tone 2  | Tone 5  |
| Tone 22 | 544Hz @ 0.875 sec. Intermittent                        | 109dB(A) @ 1m | Tone 2  | Tone 5  |
| Tone 23 | 800Hz @ 2Hz Intermittent                               | 113dB(A) @ 1m | Tone 6  | Tone 5  |
| Tone 24 | 800/1000Hz @ 50Hz Sweeping                             | 112dB(A) @ 1m | Tone 29 | Tone 5  |
| Tone 25 | 2400/2900Hz @ 50Hz Sweeping                            | 114dB(A) @ 1m | Tone 29 | Tone 5  |
| Tone 26 | Bell   | 108dB(A) @ 1m | Tone 2  | Tone 15 |
| Tone 27 | 554Hz Continuous                                       | 109dB(A) @ 1m | Tone 26 | Tone 5  |
| Tone 28 | 440Hz Continuous                                       | 106dB(A) @ 1m | Tone 2  | Tone 5  |
| Tone 29 | 800/1000Hz @ 7Hz Sweeping                              | 112dB(A) @ 1m | Tone 7  | Tone 5  |
| Tone 30 | 300Hz Continuous                                       | 107dB(A) @ 1m | Tone 2  | Tone 5  |
| Tone 31 | 660/1200Hz @ 1Hz Sweeping                              | 112dB(A) @ 1m | Tone 26 | Tone 5  |
| Tone 32 | Two tone chime.  | 108dB(A) @ 1m | Tone 26 | Tone 15 |
| Tone 33 | 745Hz @ 1Hz Intermittent                               | 109dB(A) @ 1m | Tone 2  | Tone 5  |
| Tone 34 | 1000 & 2000Hz @ 0.5 sec Alternating - Singapore        | 109dB(A) @ 1m | Tone 38 | Tone 45 |
| Tone 35 | 420Hz @ 0.625 sec Australian Alert - AS2220            | 114dB(A) @ 1m | Tone 36 | Tone 5  |
| Tone 36 | 500-1200Hz 3.75sec /0.25sec. Australian Evac. - AS2220 | 108dB(A) @ 1m | Tone 35 | Tone 5  |
| Tone 37 | 1000Hz Continuous - PFEER Toxic Gas                    | 113dB(A) @ 1m | Tone 9  | Tone 45 |
| Tone 38 | 2000Hz Continuous                                      | 112dB(A) @ 1m | Tone 34 | Tone 45 |
| Tone 39 | 800Hz 0.25sec on, 1 sec off Intermittent               | 114dB(A) @ 1m | Tone 23 | Tone 17 |
| Tone 40 | 544Hz (100mS)/440Hz (400mS) - AFNOR NF S 32-001        | 113dB(A) @ 1m | Tone 31 | Tone 27 |
| Tone 41 | Motor Siren - slow rise to 1200 Hz                     | 112dB(A) @ 1m | Tone 2  | Tone 5  |
| Tone 42 | Motor Siren - slow rise to 800 Hz                      | 114dB(A) @ 1m | Tone 2  | Tone 5  |
| Tone 43 | 1200 Hz Continuous                                     | 113dB(A) @ 1m | Tone 2  | Tone 5  |
| Tone 44 | Motor Siren - slow rise to 2400 Hz                     | 116dB(A) @ 1m | Tone 2  | Tone 5  |
| Tone 45 | 1KHz 1s on, 1s off Intermittent - PFEER Gen. Alarm     | 112dB(A) @ 1m | Tone 38 | Tone 34 |

### COMSEC PROTECTION SYSTEMS LTD.

UNIT 26, STADIUM BUSINESS PARK, • BALLYCOOLIN ROAD, • DUBLIN 11, • IRELAND

PHONE: +353 (0)1 8853008 • FAX: +353 (0)1 8853007

EMAIL: [info@comsec.ie](mailto:info@comsec.ie) • WEB: <http://www.comsec.ie>

# INSTRUCTION & SERVICE MANUAL

## E2xCS112-5EG COMBINED SOUNDER / BEACON

### For Use In Hazardous Areas

- 45 Tones 3 stage Sounder / 5 Joule Beacon
- Automatic Synchronisation
- Volume control
- IP Rating
- Operating Temperature Range  
-20°C to +55°C

**WARNING – TO AVOID A POSSIBLE ELECTROSTATIC CHARGE ONLY CLEAN THE UNIT WITH A DAMP CLOTH**

E2xCS112-5EG Sounder Section DC PCB Layout

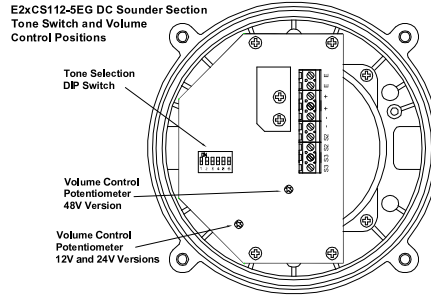

E2xCS112-5EG Beacon Section AC PCB Layout

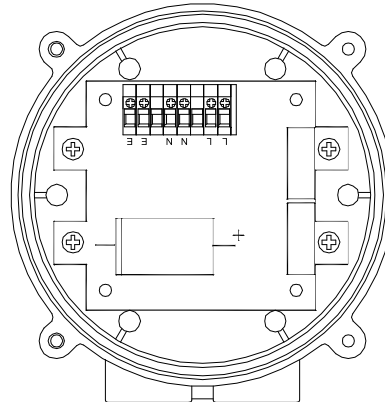

E2xCS112-5EG Beacon Section DC PCB Layout

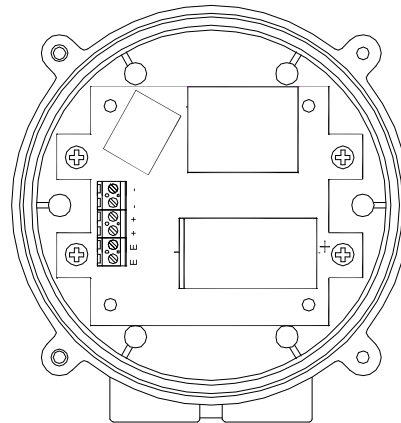

**Unit Type No.** E2xCS112-5EG

**Input Voltages:** DC Units 24V or 48V  
AC Units 120V or 230V

II 3G EEx nA nL IIC T2 (Tamb. -20°C to +55°C)  
EEx nA nL IIC T3 (Tamb. -20°C to +40°C)

**Certificate No.** DEMKO 06 ATEX 0421554

**Group/Category:** II 3G

**Zone:** Zone 2

**PRE-INSTALLATION**

The E2xCS112-5EG combined sounder / beacons must be installed in accordance with the relevant parts of the EN60079 standards or the equivalent IEC standards. *Note the units are factory set to tone 2 (800/1000Hz alternating at 2Hz) and maximum output.* If necessary the unit should be connected to a suitable power supply in a safe area to determine what tone pattern and output level is required.

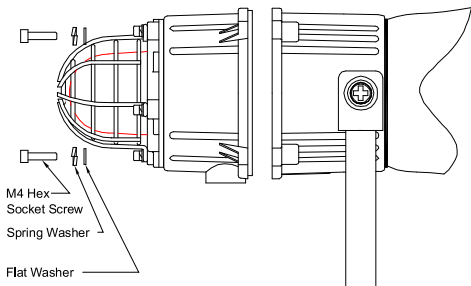

**WARNING – DO NOT OPEN WHEN ENERGISED**

E2xCS112-5EG Sounder Section AC PCB Layout

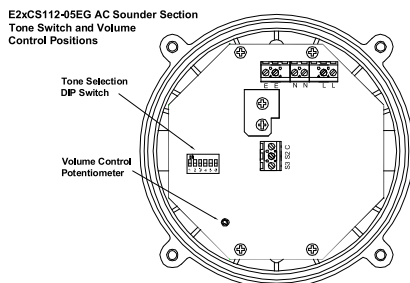

## MOUNTING

The E2xCS112-5EG combined sounder / beacon must be mounted using the rotating bracket as shown.

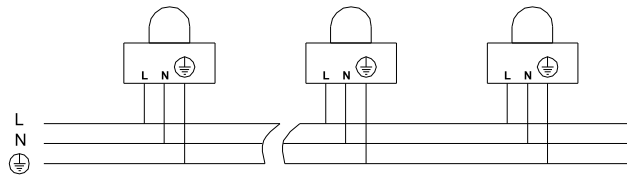
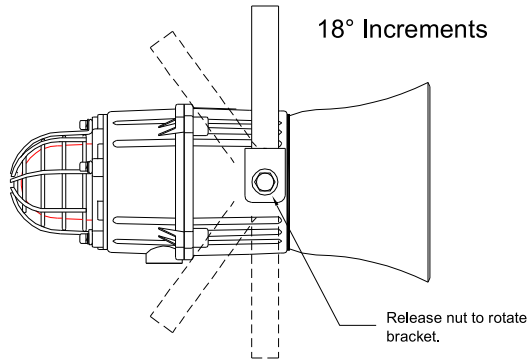

### DC Sounder Section

Positive +  
 Negative -  
 Stage 2 S2  
 Stage 3 S3

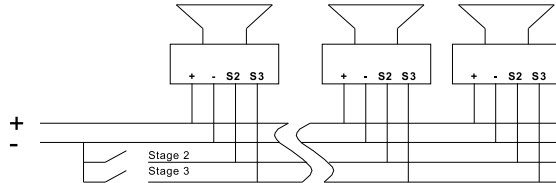

### DC Beacon Section

Positive +  
 Negative -  
 Earth E

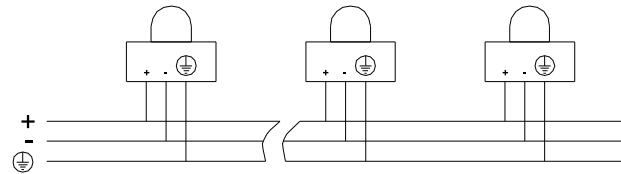

## WIRING

The E2xCS112-5EG combined sounder / beacon has two M20 cable entries one of which is fitted with an M20 blanking plug. This should be removed if two cable entries are required. Cable entry devices shall be used which ensure a minimum ingress protection of IP54.

The cable connections are made to the terminal blocks on the pcb assemblies in both the sounder and beacon sections of the enclosure. On AC units the sounder pcb has a six way terminal block for the Mains Input Supply and a separate three way terminal block for selecting the second and third stage outputs if required. On DC units the sounder pcb has a ten way terminal block for both the DC supply and the second and third stages.

**WARNING - ALL ELECTRICAL WIRING MUST BE INSTALLED IN ACCORDANCE WITH THE RELEVANT STANDARDS AND ANY LOCAL CODES THAT MAY APPLY**

### AC Sounder Section

Live L Common C  
 Neutral N Stage 2 S2  
 Earth E Stage 3 S3

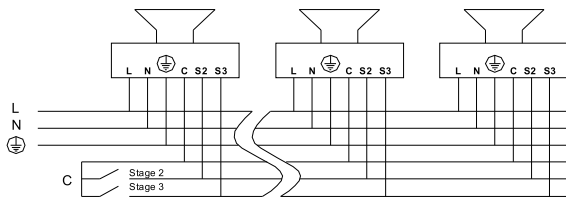

### AC Beacon Section

Live L  
 Neutral N  
 Ground E

## POWER SUPPLY SELECTION

It is important that a suitable power supply is used to run the combined units. The power supply selected must have the necessary capacity to provide the input current to all of the units connected to the system.

### Sounder Section

| Unit Type    | Input Voltage | Input @ 1kHz Current | Max. I/P Volts |
|--------------|---------------|----------------------|----------------|
| E2xCS112-5EG | 24V DC        | 284mA                | 30V            |
| E2xCS112-5EG | 48V DC        | 146mA                | 58V            |
| E2xCS112-5EG | 230V AC       | 54mA                 | 253V           |
| E2xCS112-5EG | 120V AC       | 104mA                | 132V           |

### Beacon Section

| Unit Type    | Input Voltage | Input Current | Max. I/P Volts |
|--------------|---------------|---------------|----------------|
| E2xCS112-5EG | 24V DC        | 275mA         | 30V            |
| E2xCS112-5EG | 48V DC        | 145mA         | 58V            |
| E2xCS112-5EG | 230V AC       | 30mA          | 253V           |
| E2xCS112-5EG | 120V AC       | 80mA          | 132V           |

## TONE SELECTION

The E2xCS112-5EG sounder section has 45 different tones that can be selected for the first stage alarm. The sounder can then be switched to sound second and third stage alarm tones. The tones are selected by operation of a DIP switch on the pcb for both DC and AC units. The tone table shows the switch positions for the 45 tones and which tones are available for the second and third stages. To operate the sounder on stage one simply connect the supply voltage to the + & - terminals for DC units and the L, N & E terminals for AC units.

The operation of the second and third stages is different for DC and AC units.

### DC Units Second and Third Stage Tone Selection

To activate the second stage, remotely switch the negative supply to the S2 terminal. To activate the third stage, remotely switch the negative supply to the S3 terminal. NOTE the DC power supply to the + & - terminals must be maintained for 2<sup>nd</sup> and 3<sup>rd</sup> stages.

### AC Units Second and Third Stage Tone Selection

To select the second and third stages on the E2xS121EG AC sounders the Common (C) terminal must be remotely connected to the S2 terminal for the second stage and to the S3 terminal for third stage. NOTE the AC power supply to the L, N & E terminals must be maintained for 2<sup>nd</sup> and 3<sup>rd</sup> stages.

## VOLUME CONTROL

The volume on the E2xCS112-5EG sounder can be set using the volume control (see sounder pcb layouts on page 1). For maximum output level the potentiometer should be set to the fully clockwise position.

## **WARNING – HIGH VOLUME MAY CAUSE HARM TO PERSONNEL IN CLOSE PROXIMITY**

## TONE SELECTION TABLE

| Stage 1 | Frequency Description                                 | Switch |   |   |   |   |   | Stage 2 | Stage 3 |
|---------|---|--------|---|---|---|---|---|---------|---------|
|         |   | 1      | 2 | 3 | 4 | 5 | 6 |         |         |
| 1       | 340Hz Continuous                                      | 0      | 0 | 0 | 0 | 0 | 0 | Tone 2  | Tone 5  |
| 2       | 800/1000Hz @ 0.25 sec Alternating                     | 1      | 0 | 0 | 0 | 0 | 0 | Tone 17 | Tone 5  |
| 3       | 500/1200Hz @ 0.3Hz sec Slow Whoop                     | 0      | 1 | 0 | 0 | 0 | 0 | Tone 2  | Tone 5  |
| 4       | 800/1000Hz @ 1Hz Sweeping                             | 1      | 1 | 0 | 0 | 0 | 0 | Tone 6  | Tone 5  |
| 5       | 2400Hz Continuous                                     | 0      | 0 | 1 | 0 | 0 | 0 | Tone 3  | Tone 20 |
| 6       | 2400/2900Hz @ 7Hz Sweeping                            | 1      | 0 | 1 | 0 | 0 | 0 | Tone 7  | Tone 5  |
| 7       | 2400/2900Hz @ 1Hz Sweeping                            | 0      | 1 | 1 | 0 | 0 | 0 | Tone 10 | Tone 5  |
| 8       | 500/1200/500Hz @ 0.3Hz Sweeping                       | 1      | 1 | 1 | 0 | 0 | 0 | Tone 2  | Tone 5  |
| 9       | 1200/500Hz @ 1Hz - DIN PFEER P.T.A.P.                 | 0      | 0 | 0 | 1 | 0 | 0 | Tone 15 | Tone 2  |
| 10      | 2400/2900Hz @ 2Hz Alternating                         | 1      | 0 | 0 | 1 | 0 | 0 | Tone 7  | Tone 5  |
| 11      | 1000Hz @ 1Hz Intermittent                             | 0      | 1 | 0 | 1 | 0 | 0 | Tone 2  | Tone 5  |
| 12      | 800/1000Hz @ 0.875Hz Alternating                      | 1      | 1 | 0 | 1 | 0 | 0 | Tone 4  | Tone 5  |
| 13      | 2400Hz @ 1Hz Intermittent                             | 0      | 0 | 1 | 1 | 0 | 0 | Tone 15 | Tone 5  |
| 14      | 800Hz 0.25 sec on, 1 sec off Intermittent             | 1      | 0 | 1 | 1 | 0 | 0 | Tone 4  | Tone 5  |
| 15      | 800Hz Continuous                                      | 0      | 1 | 1 | 1 | 0 | 0 | Tone 2  | Tone 5  |
| 16      | 660Hz 150mS on, 150mS off Intermittent                | 1      | 1 | 1 | 1 | 0 | 0 | Tone 18 | Tone 5  |
| 17      | 544Hz (100mS)/440 Hz (400mS) - NF S 32-001            | 0      | 0 | 0 | 0 | 1 | 0 | Tone 2  | Tone 27 |
| 18      | 660Hz 1.8 sec on, 1.8 sec off Intermittent            | 1      | 0 | 0 | 0 | 1 | 0 | Tone 2  | Tone 5  |
| 19      | 1.4KHz - 1.6KHz 1s, 1.6KHz - 1.4 KHz 0.5s - NFC48-265 | 0      | 1 | 0 | 0 | 1 | 0 | Tone 2  | Tone 5  |
| 20      | 660Hz Continuous                                      | 1      | 1 | 0 | 0 | 1 | 0 | Tone 2  | Tone 5  |
| 21      | 554Hz/440Hz @ 1Hz Alternating                         | 0      | 0 | 1 | 0 | 1 | 0 | Tone 2  | Tone 5  |
| 22      | 544Hz @ 0.875 sec Intermittent                        | 1      | 0 | 1 | 0 | 1 | 0 | Tone 2  | Tone 5  |
| 23      | 800Hz @ 2Hz Intermittent                              | 0      | 1 | 1 | 0 | 1 | 0 | Tone 6  | Tone 5  |
| 24      | 800/1000Hz @ 50Hz Sweeping                            | 1      | 1 | 1 | 0 | 1 | 0 | Tone 29 | Tone 5  |
| 25      | 2400/2900Hz @ 50Hz Sweeping                           | 0      | 0 | 0 | 1 | 1 | 0 | Tone 29 | Tone 5  |
| 26      | Bell  | 1      | 0 | 0 | 1 | 1 | 0 | Tone 2  | Tone 15 |
| 27      | 554Hz Continuous                                      | 0      | 1 | 0 | 1 | 1 | 0 | Tone 26 | Tone 5  |
| 28      | 440Hz Continuous                                      | 1      | 1 | 0 | 1 | 1 | 0 | Tone 2  | Tone 5  |
| 29      | 800/1000Hz @ 7Hz Sweeping                             | 0      | 0 | 1 | 1 | 1 | 0 | Tone 7  | Tone 5  |
| 30      | 300Hz Continuous                                      | 1      | 0 | 1 | 1 | 1 | 0 | Tone 2  | Tone 5  |
| 31      | 660/1200Hz @ 1Hz Sweeping                             | 0      | 1 | 1 | 1 | 1 | 0 | Tone 26 | Tone 5  |
| 32      | Two tone chime  | 1      | 1 | 1 | 1 | 1 | 0 | Tone 26 | Tone 15 |
| 33      | 745Hz @ 1Hz Intermittent                              | 0      | 0 | 0 | 0 | 1 | 0 | Tone 2  | Tone 5  |
| 34      | 1000 & 2000Hz @ 0.5 sec Alternating - Singapore       | 1      | 0 | 0 | 0 | 0 | 1 | Tone 38 | Tone 45 |
| 35      | 420Hz @ 0.625 Sec Australian Alert                    | 0      | 1 | 0 | 0 | 0 | 1 | Tone 36 | Tone 5  |
| 36      | 500-1200Hz 3.75 sec /0.25 sec Australian Evac.        | 1      | 1 | 0 | 0 | 0 | 1 | Tone 35 | Tone 5  |
| 37      | 1000Hz Continuous - PFEER Toxic Gas                   | 0      | 0 | 1 | 0 | 0 | 1 | Tone 9  | Tone 45 |
| 38      | 2000Hz Continuous                                     | 1      | 0 | 1 | 0 | 0 | 1 | Tone 34 | Tone 45 |
| 39      | 800Hz 0.25 sec on, 1 sec off Intermittent             | 0      | 1 | 1 | 0 | 0 | 1 | Tone 23 | Tone 17 |
| 40      | 544Hz (100mS)/440Hz (400mS) - NF S 32-001             | 1      | 1 | 1 | 0 | 0 | 1 | Tone 31 | Tone 27 |
| 41      | Motor Siren - slow rise to 1200Hz                     | 0      | 0 | 0 | 1 | 0 | 1 | Tone 2  | Tone 5  |
| 42      | Motor Siren - slow rise to 800Hz                      | 1      | 0 | 0 | 1 | 0 | 1 | Tone 2  | Tone 5  |
| 43      | 1200Hz Continuous                                     | 0      | 1 | 0 | 1 | 0 | 1 | Tone 2  | Tone 5  |
| 44      | Motor Siren - slow rise to 2400Hz                     | 1      | 1 | 0 | 1 | 0 | 1 | Tone 2  | Tone 5  |
| 45      | 1KHz 1s on, 1s off Intermittent - PFEER Gen. Alarm    | 0      | 0 | 1 | 1 | 0 | 1 | Tone 38 | Tone 34 |

## SWITCH POSITION EXPLANATION

1 = Switch in the ON position.  
0 = Switch in the OFF position..

# INSTRUCTION & SERVICE MANUAL

## E2xCS112-5UL COMBINED

### ALARM HORN SOUNDER / BEACON

### For Use In Hazardous Locations

- 45 Tones 3 stage Alarm Horn Sounder / 5 Joule Beacon
- Automatic Synchronisation (sounder)
- Volume control
- Type 4 / 4X / 13
- Operating Temperature Range -20°C to +55°C



Unit Type No. E2xCS112-5UL

7KA1

**Input Voltages:** DC Units 12V or 24V or 48V  
AC Units 120V or 230V 50/60Hz

| Max. Operating Temperature / Code at +55° Ambient |                  |
|---|------------------|
| Hazardous Location                                | Temperature Code |
| Class I, Division 2, Groups A, B, C, D            | T2D (215°C)      |
| Class II, Division 2, Groups F and G              | T6 (85°C)        |
| Class III, Divisions 1 and 2                      | T6 (85°C)        |

| Max. Operating Temperature / Code at +40° Ambient |                  |
|---|------------------|
| Hazardous Location                                | Temperature Code |
| Class I, Division 2, Groups A, B, C, D            | T3 (200°C)       |

The equipment is suitable for use in the hazardous locations listed above or non-hazardous locations only.

#### PRE-INSTALLATION

**WARNING** - Before the E2xCS112-5UL combined sounder / beacon is installed the required tone and output volume must be set. *Note the units are factory set to tone 2 (800/1000Hz alternating at 2Hz) and maximum output.* If necessary the unit should be connected to a suitable power supply in a safe area to determine what tone pattern and output level is required.

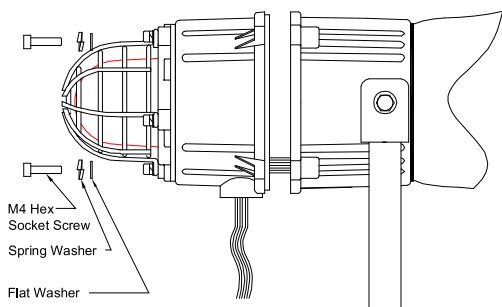

**WARNING – NOT TO BE USED AS A VISUAL PUBLIC MODE NOTIFICATION APPLIANCE**

**WARNING – HIGH VOLTAGE SHOCK HAZARD. WAIT 5 MINUTES AFTER REMOVING POWER BEFORE OPENING THE ENCLOSURE**

E2xCS112-05UL DC Sounder Section  
Tone Switch and Volume Control Positions

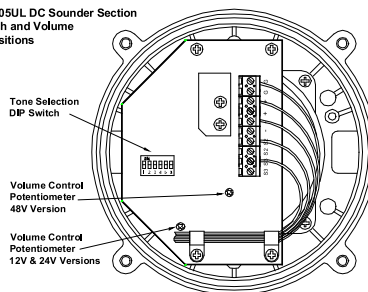

E2xCS112-05UL AC Sounder Section  
Tone Switch and Volume Control Positions

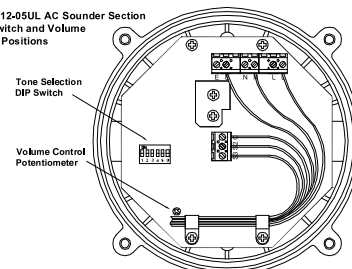

**WARNING - EXPLOSION HAZARD - SUBSTITUTION OF COMPONENTS MAY IMPAIR SUITABILITY FOR CLASS I, II DIVISION 2.**

#### MOUNTING

The E2xCS112-5UL combined sounder / beacon must be mounted using the rotating bracket as shown. If the cover has been removed to set the tone or volume control ensure that it has been correctly replace before the sounder is mounted.

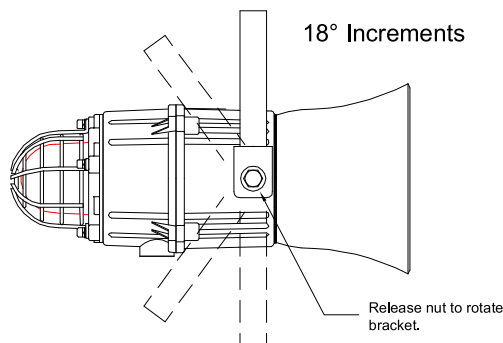

#### WIRING INSTALLATION

The E2xCS112-5UL combined sounder /beacon has one 1/2 NPT cable entry, the blanking plug adjacent to the cable entry is permanently fixed and must not be removed. The combined unit is pre-wired with flying leads which are colour coded and should be connected as shown in the diagram below.

The conduit running from the supply to the combined unit must include an equipment grounding conductor that is at earth potential to facilitate ground connection of the device. A number of combined units can be connected in a chain to the same supply using field installed wiring compartments that are

appropriate for the hazardous location, provided that the conductor at earth potential can be readily connected to the ground lead on each combined unit in the chain.

**WARNING - ALL ELECTRICAL WIRING MUST BE INSTALLED IN ACCORDANCE TO THE NATIONAL ELECTRICAL CODE**

**AC Sounder Section**

|                  |         |            |    |
|------------------|---------|------------|----|
| Black (S)        | Live    | Violet (S) | C  |
| White (S)        | Neutral | Orange (S) | S2 |
| Green/Yellow (S) | Ground  | Yellow (S) | S3 |

**AC Beacon Section**

|                  |         |
|------------------|---------|
| Black (B)        | Live    |
| White (B)        | Neutral |
| Green/Yellow (B) | Ground  |

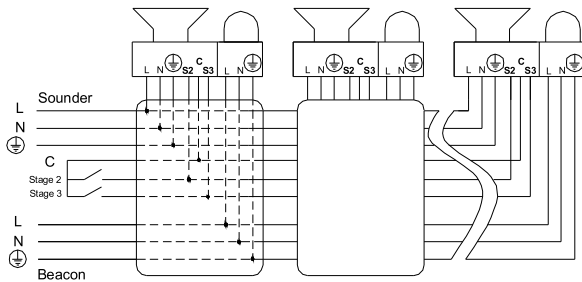

NOTE if the second and third stage wires are not used they must be individually insulated to ensure that cannot make contact to any other wires.

**DC Sounder Section**

|                  |          |
|------------------|----------|
| Red (S)          | Positive |
| Black (S)        | Negative |
| Orange (S)       | S2       |
| Yellow (S)       | S3       |
| Green/Yellow (S) | Ground   |

**DC Beacon Section**

|                  |          |
|------------------|----------|
| Red (B)          | Positive |
| Black (B)        | Negative |
| Green/Yellow (B) | Ground   |

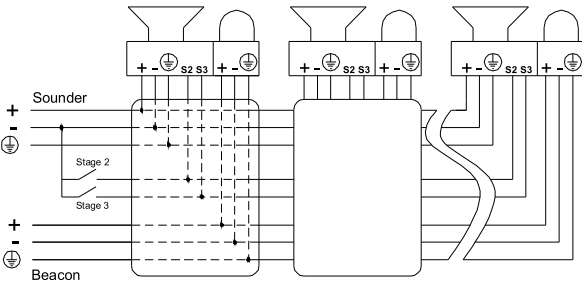

NOTE if the second and third stage wires are not used they must be individually insulated to ensure that cannot make contact to any other wires.

**POWER SUPPLY SELECTION**

It is important that a suitable power supply is used to run the combined units. The power supply selected must have the necessary capacity to provide the input current to all of the units connected to the system.

**Sounder Section**

| Unit Type    | Input Voltage   | Input @ 1kHz Current | Max. I/P Volts |
|--------------|-----------------|----------------------|----------------|
| E2xCS112-5UL | 24V DC          | 284mA                | 30V            |
| E2xCS112-5UL | 48V DC          | 146mA                | 58V            |
| E2xCS112-5UL | 230V 50/60Hz AC | 54mA                 | 253V           |
| E2xCS112-5UL | 120V 50/60Hz AC | 104mA                | 132V           |

**Beacon Section**

| Unit Type    | Input Voltage   | Input Current | Max. I/P Volts |
|--------------|-----------------|---------------|----------------|
| E2xCS112-5UL | 24V DC          | 275mA         | 30V            |
| E2xCS112-5UL | 48V DC          | 145mA         | 58V            |
| E2xCS112-5UL | 230V 50/60Hz AC | 30mA          | 253V           |
| E2xCS112-5UL | 120V 50/60Hz AC | 80mA          | 132V           |

**TONE SELECTION**

The E2xCS112-5UL sounder section has 45 different tones that can be selected for the first stage alarm. The sounder can then be switched to sound second and third stage alarm tones. The tones are selected by operation of a DIP switch on the pcb in the sounder section for both DC and AC units. The tone table shows the switch positions for the 45 tones and which tones are available for the second and third stages. To operate the sounder on stage one simply connect the supply voltage to the flying leads Red (S) and Black (S) for DC units, Black (S), White (S) and Green/Yellow for AC units.

The operation of the second and third stages is different for DC and AC units.

DC Units Second and Third Stage Tone Selection

To activate the second stage, remotely switch the S2 orange wire to the negative supply. To activate the third stage, remotely switch the S3 orange wire to the negative supply. NOTE the DC power supply to the Red (S) and Black (S) wires must be maintained for 2<sup>nd</sup> and 3<sup>rd</sup> stages.

AC Units Second and Third Stage Tone Selection

To select the second and third stages on the E2xCS112-5UL AC sounder the Common (C) Violet wire must be remotely connected to the S2 orange wire for the second stage and to the S3 yellow wire for third stage. NOTE the AC power supply to the Black (S) and White (S) wires must be maintained for 2<sup>nd</sup> and 3<sup>rd</sup> stages.

**VOLUME CONTROL**

The volume on the E2xCS112-5UL sounder can be set using the volume control (see figures 2 and 3). For maximum output level the potentiometer should be set to the fully clockwise position.

**WARNING – HIGH VOLUME MAY CAUSE HARM TO PERSONNEL IN CLOSE PROXIMITY**

COMSEC PROTECTION SYSTEMS LTD.  
 UNIT 26, STADIUM BUSINESS PARK, • BALLYCOOLIN ROAD, • DUBLIN 11, • IRELAND  
 PHONE: +353 (0)1 8853008 • FAX: +353 (0)1 8853007  
 EMAIL: [info@comsec.ie](mailto:info@comsec.ie) • WEB: <http://www.comsec.ie>

## TONE SELECTION TABLE

| Stage 1 | Frequency Description                                 | Switch |   |   |   |   |   | Stage 2 | Stage 3 |
|---------|---|--------|---|---|---|---|---|---------|---------|
|         |   | 1      | 2 | 3 | 4 | 5 | 6 |         |         |
| 1       | 340Hz Continuous                                      | 0      | 0 | 0 | 0 | 0 | 0 | Tone 2  | Tone 5  |
| 2       | 800/1000Hz @ 0.25 sec Alternating                     | 1      | 0 | 0 | 0 | 0 | 0 | Tone 17 | Tone 5  |
| 3       | 500/1200Hz @ 0.3Hz sec Slow Whoop                     | 0      | 1 | 0 | 0 | 0 | 0 | Tone 2  | Tone 5  |
| 4       | 800/1000Hz @ 1Hz Sweeping                             | 1      | 1 | 0 | 0 | 0 | 0 | Tone 6  | Tone 5  |
| 5       | 2400Hz Continuous                                     | 0      | 0 | 1 | 0 | 0 | 0 | Tone 3  | Tone 20 |
| 6       | 2400/2900Hz @ 7Hz Sweeping                            | 1      | 0 | 1 | 0 | 0 | 0 | Tone 7  | Tone 5  |
| 7       | 2400/2900Hz @ 1Hz Sweeping                            | 0      | 1 | 1 | 0 | 0 | 0 | Tone 10 | Tone 5  |
| 8       | 500/1200/500Hz @ 0.3Hz Sweeping                       | 1      | 1 | 1 | 0 | 0 | 0 | Tone 2  | Tone 5  |
| 9       | 1200/500Hz @ 1Hz - DIN PFEER P.T.A.P.                 | 0      | 0 | 0 | 1 | 0 | 0 | Tone 15 | Tone 2  |
| 10      | 2400/2900Hz @ 2Hz Alternating                         | 1      | 0 | 0 | 1 | 0 | 0 | Tone 7  | Tone 5  |
| 11      | 1000Hz @ 1Hz Intermittent                             | 0      | 1 | 0 | 1 | 0 | 0 | Tone 2  | Tone 5  |
| 12      | 800/1000Hz @ 0.875Hz Alternating                      | 1      | 1 | 0 | 1 | 0 | 0 | Tone 4  | Tone 5  |
| 13      | 2400Hz @ 1Hz Intermittent                             | 0      | 0 | 1 | 1 | 0 | 0 | Tone 15 | Tone 5  |
| 14      | 800Hz 0.25 sec on, 1 sec off Intermittent             | 1      | 0 | 1 | 1 | 0 | 0 | Tone 4  | Tone 5  |
| 15      | 800Hz Continuous                                      | 0      | 1 | 1 | 1 | 0 | 0 | Tone 2  | Tone 5  |
| 16      | 660Hz 150mS on, 150mS off Intermittent                | 1      | 1 | 1 | 1 | 0 | 0 | Tone 18 | Tone 5  |
| 17      | 544Hz (100mS)/440 Hz (400mS) - NF S 32-001            | 0      | 0 | 0 | 1 | 0 | 0 | Tone 2  | Tone 27 |
| 18      | 660Hz 1.8 sec on, 1.8 sec off Intermittent            | 1      | 0 | 0 | 0 | 1 | 0 | Tone 2  | Tone 5  |
| 19      | 1.4KHz - 1.6KHz 1s, 1.6KHz - 1.4 KHz 0.5s - NFC48-265 | 0      | 1 | 0 | 0 | 1 | 0 | Tone 2  | Tone 5  |
| 20      | 660Hz Continuous                                      | 1      | 1 | 0 | 0 | 1 | 0 | Tone 2  | Tone 5  |
| 21      | 554Hz/440Hz @ 1Hz Alternating                         | 0      | 0 | 1 | 0 | 1 | 0 | Tone 2  | Tone 5  |
| 22      | 544Hz @ 0.875 sec Intermittent                        | 1      | 0 | 1 | 0 | 1 | 0 | Tone 2  | Tone 5  |
| 23      | 800Hz @ 2Hz Intermittent                              | 0      | 1 | 1 | 0 | 1 | 0 | Tone 6  | Tone 5  |
| 24      | 800/1000Hz @ 50Hz Sweeping                            | 1      | 1 | 1 | 0 | 1 | 0 | Tone 29 | Tone 5  |
| 25      | 2400/2900Hz @ 50Hz Sweeping                           | 0      | 0 | 0 | 1 | 1 | 0 | Tone 29 | Tone 5  |
| 26      | Bell  | 1      | 0 | 0 | 1 | 1 | 0 | Tone 2  | Tone 15 |
| 27      | 554Hz Continuous                                      | 0      | 1 | 0 | 1 | 1 | 0 | Tone 26 | Tone 5  |
| 28      | 440Hz Continuous                                      | 1      | 1 | 0 | 1 | 1 | 0 | Tone 2  | Tone 5  |
| 29      | 800/1000Hz @ 7Hz Sweeping                             | 0      | 0 | 1 | 1 | 1 | 0 | Tone 7  | Tone 5  |
| 30      | 300Hz Continuous                                      | 1      | 0 | 1 | 1 | 1 | 0 | Tone 2  | Tone 5  |
| 31      | 660/1200Hz @ 1Hz Sweeping                             | 0      | 1 | 1 | 1 | 1 | 0 | Tone 26 | Tone 5  |
| 32      | Two tone chime  | 1      | 1 | 1 | 1 | 1 | 0 | Tone 26 | Tone 15 |
| 33      | 745Hz @ 1Hz Intermittent                              | 0      | 0 | 0 | 0 | 1 | 0 | Tone 2  | Tone 5  |
| 34      | 1000 & 2000Hz @ 0.5 sec Alternating - Singapore       | 1      | 0 | 0 | 0 | 0 | 1 | Tone 38 | Tone 45 |
| 35      | 420Hz @ 0.625 Sec Australian Alert                    | 0      | 1 | 0 | 0 | 0 | 1 | Tone 36 | Tone 5  |
| 36      | 500-1200Hz 3.75 sec /0.25 sec Australian Evac.        | 1      | 1 | 0 | 0 | 0 | 1 | Tone 35 | Tone 5  |
| 37      | 1000Hz Continuous - PFEER Toxic Gas                   | 0      | 0 | 1 | 0 | 0 | 1 | Tone 9  | Tone 45 |
| 38      | 2000Hz Continuous                                     | 1      | 0 | 1 | 0 | 0 | 1 | Tone 34 | Tone 45 |
| 39      | 800Hz 0.25 sec on, 1 sec off Intermittent             | 0      | 1 | 1 | 0 | 0 | 1 | Tone 23 | Tone 17 |
| 40      | 544Hz (100mS)/440Hz (400mS) - NF S 32-001             | 1      | 1 | 1 | 0 | 0 | 1 | Tone 31 | Tone 27 |
| 41      | Motor Siren - slow rise to 1200Hz                     | 0      | 0 | 0 | 1 | 0 | 1 | Tone 2  | Tone 5  |
| 42      | Motor Siren - slow rise to 800Hz                      | 1      | 0 | 0 | 1 | 0 | 1 | Tone 2  | Tone 5  |
| 43      | 1200Hz Continuous                                     | 0      | 1 | 0 | 1 | 0 | 1 | Tone 2  | Tone 5  |
| 44      | Motor Siren - slow rise to 2400Hz                     | 1      | 1 | 0 | 1 | 0 | 1 | Tone 2  | Tone 5  |
| 45      | 1KHz 1s on, 1s off Intermittent - PFEER Gen. Alarm    | 0      | 0 | 1 | 1 | 0 | 1 | Tone 38 | Tone 34 |

## SWITCH POSITION EXPLANATION

1 = Switch in the ON position.  
0 = Switch in the OFF position..

## END OF LINE MONITORING

On E2xCS112-5UL DC units, dc reverse line monitoring can be used on both the sounder section and the beacon section if required. All DC combined units have a blocking diode fitted in the supply input lines to both the sounder and the beacon. An end of line monitoring resistor can be connected across the +ve and -ve terminals. If an end of line resistor is used it must have the following values:-

### 24V DC Sounders

Minimum Resistance 3k9 ohms      Minimum wattage 0.5W  
Minimum Resistance 1k ohms      Minimum wattage 2.0W

### 48V DC Sounders

Minimum Resistance 15k ohms      Minimum wattage 0.5W  
Minimum Resistance 3k9 ohms      Minimum wattage 2.0W

The resistor must be connected directly across the +ve and -ve terminals as shown in the following drawings. Whilst keeping its leads as short as possible, a spacing of at least 1/16 inch (1.58mm) must be provided through air and over surfaces between uninsulated live parts.

E2xCS112-5UL DC  
Sounder Section  
End of Line Resistor

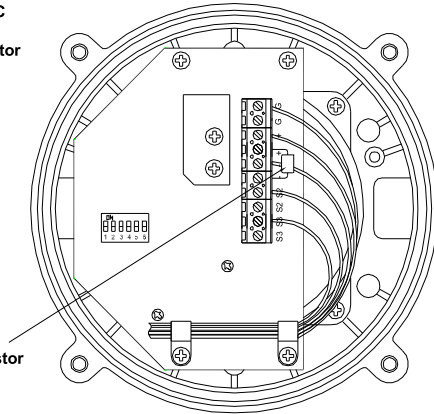

End of Line Resistor

E2xCS112-5UL DC  
Beacon Section  
End of Line Resistor

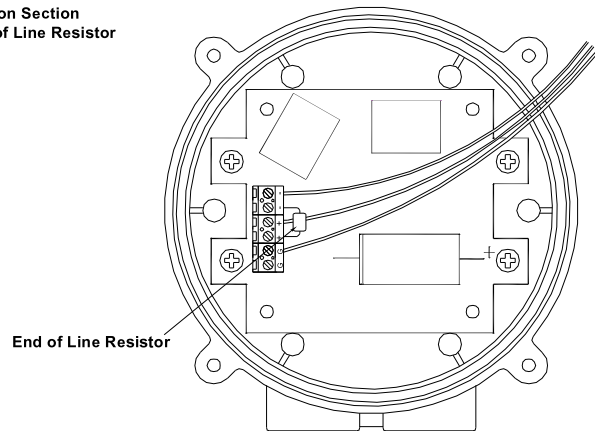

End of Line Resistor

**COMSEC PROTECTION SYSTEMS LTD.**  
UNIT 26, STADIUM BUSINESS PARK, • BALLYCOOLIN ROAD, • DUBLIN 11, • IRELAND  
PHONE: +353 (0)1 8853008 • FAX: +353 (0)1 8853007  
EMAIL: info@comsec.ie • WEB: http://www.comsec.ie