

BExCS110-L1 / BExDCS110-L1

Sounder & L.E.D

The flameproof BExCS110-L1 combination alarm sounders and high output L.E.D. beacons are suitable for Zone 1 & Zone 2 applications. The BExDCS110-L1 is suitable for Zone 1, 2, 21 & 22 applications.

The BExCS110-L1 features sound level outputs of up to 117dB(A) at 1 metre with a choice of 32 alarm tones and 3 remotely selectable stages. The beacon contains an array of 32 high output, multi-function L.E.D.s with a total of 9 modes of operation - 4 rotating effect modes, 4 flashing modes and a steady mode for use in indicator / status applications. Based on the mode selected the user can also select two alternative L.E.D. modes remotely.

Features:

- Glass dome with optically enhanced prismatic PC lens
- Stainless Steel guard
- Very large termination area.
- Ratchet adjustable stainless steel 'U' bracket.
- The sounder & beacon may be connected from a single supply for simultaneous operation or from separate supplies for independent operation
- 'Programmable' version available:
 - 45 alarm tones
 - 4 remotely selectable stages
 - Any tone can be assigned to any stage
 - User configurable continuous frequency tone

Approvals:

- ATEX certificate: KEMA 01ATEX2223X, EN 60079-0 : 2006, EN 60079-1 : 2007, EN 61241-0 : 2006, EN 61241-1 : 2004
- IECEx certificate: IECEx KEM 10.0025, IEC 60079-0 : 2004 (Ed4), IEC 60079-1 : 2007 (Ed6), IEC 61241-0 : 2004 (Ed1), IEC 61241-1 : 2004 (Ed1)
- GOST-R certificate: POCC GB.JB05.B02205
- Safety-integrity suitability: SIL1

Multi-function patterns:

Mode:	Stage 1: [Selectable on board]	Stage 2: [Remotely selectable]	Stage 3: [Remotely selectable]
1	All L.E.D's on	Mode: 9	Mode: 6
2	Rotating: Slow1	Mode: 9	Mode: 1
3	Single Strike Flash: 2Hz	Mode: 7	Mode: 1
4	Rotating: Fast 1	Mode: 3	Mode: 1
5	Rotating: Slow 2	Mode: 6	Mode: 1
6	Double Strike Flash: 1Hz	Mode: 7	Mode: 1
7	Rotating: Fast 2	Mode: 8	Mode: 1
8	Double Strike Flash: 2Hz	Mode: 9	Mode: 1
9	Alternate Side Flash: 2Hz	Mode: 7	Mode: 1

Part codes:

Part Code:	Classification:
BExCS110L1D**	ATEX / IECEx: II 2G Ex d IIB T4 Ta. -50° to +70°C GOST-R: 1ExdIIBT4 Ta. -50° to +55°C
BExDCS110L1D**	ATEX / IECEx: II 2G Ex d IIB T4 Ta. -50°C to. +70°C II 2D Ex tD A21 IP67 T115°C based on max Ta. of +70°C GOST-R: 1ExdIIBT4 Ta. -50° to +55°C DIP A21 Ta T5

** = Voltage reference:

Options:	12DC, 24DC, 48DC, 115AC, 230AC
Add 'P' to part number for Programmable version	



COMSEC PROTECTION SYSTEMS LTD.
 UNIT 26, STADIUM BUSINESS PARK, • BALLYCOOLIN ROAD, • DUBLIN 11, • IRELAND
 PHONE: +353 (0)1 8853008 • FAX: +353 (0)1 8853007
 EMAIL: info@comsec.ie • WEB: http://www.comsec.ie

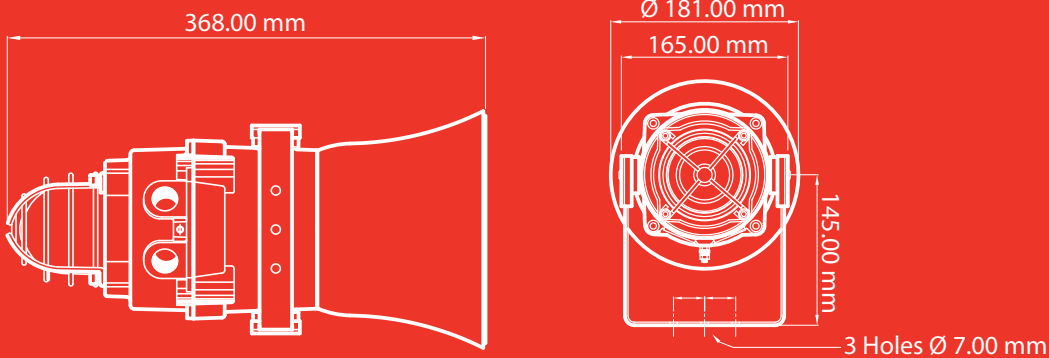

Specification:

Sounder/Horn:

Maximum output:	117dB(A) @ 1 metre
Nominal output:	110dB(A) @ 1m +/- 3dB - Tone 2
No. of tones:	32 (UKOOA / PFEER compliant)
No. of stages:	3
Volume control:	Max. 110dB(A); Min. 72dB(A) - Tone 2
Effective range:	100m @ 1KHz
Voltages DC:	12V dc; 24V dc; 48V dc
Voltages AC:	115V ac; 230V ac
Stage switching:	Negative or positive

L.E.D. Beacon:

Light source:	Array of 32 high output L.E.D.s
Effective Candela:	11 cd*
Lens colours:	Amber, Blue, Green, Red & Yellow
Voltages DC:	10-50V dc
Voltages AC:	115V ac; 230V ac

General:

Ingress protection:	IP66/67
Housing material:	Marine grade copper free LM6 Aluminium
Housing finish:	Phosphated & powder coated
BExCS110-L1 flare:	High impact UL94 V0 & 5VA FR ABS (Red)
BExDCS110-L1 flare:	Anti-Static High impact ABS (Black)
Cable entries:	Dual M20 ISO (one stopping plug included)
Terminals:	0.5 to 4.0mm ² cables.
Line monitoring :	Min. 500 Ohm 2w, or 3k3 Ohm 0.5w res. or diode (dc versions).
Weight :	5.00kg

Stage1 Frequency Description

Stage1	Frequency Description	dB @ 1m*	Stage2	Stage3
Tone 1	1000 Hz Continuous - PFEER Toxic Gas	110.0dB(A) @ 1m	Tone 31	Tone 11
Tone 2	800/1000Hz @ 0.25 sec Alternating	110.0dB(A) @ 1m	Tone 17	Tone 5
Tone 3	500/1200Hz @ 0.3Hz 0.5 sec Slow Whoop	110.5dB(A) @ 1m	Tone 2	Tone 5
Tone 4	800/1000Hz @ 1Hz Sweeping	110.0dB(A) @ 1m	Tone 6	Tone 5
Tone 5	2400Hz Continuous	109.0dB(A) @ 1m	Tone 3	Tone 27
Tone 6	2400/2900Hz @ 7Hz Sweeping	109.0dB(A) @ 1m	Tone 7	Tone 5
Tone 7	2400/2900Hz @ 1Hz Sweeping	110.0dB(A) @ 1m	Tone 10	Tone 5
Tone 8	500/1200/500Hz @ 0.3Hz Sweeping	110.5dB(A) @ 1m	Tone 2	Tone 5
Tone 9	1200/500Hz @ 1Hz - DIN / PFEER P.T.A.P.	110.5dB(A) @ 1m	Tone 15	Tone 2
Tone 10	2400/2900Hz @ 2Hz Alternating	109.0dB(A) @ 1m	Tone 7	Tone 5
Tone 11	1000Hz @ 0.5Hz Intermittent	110.0dB(A) @ 1m	Tone 31	Tone 1
Tone 12	800/1000Hz @ 0.875Hz Alternating	110.0dB(A) @ 1m	Tone 4	Tone 5
Tone 13	2400Hz @ 1Hz Intermittent	109.0dB(A) @ 1m	Tone 15	Tone 5
Tone 14	800Hz 0.25sec on, 1 sec off Intermittent	103.0dB(A) @ 1m	Tone 4	Tone 5
Tone 15	800Hz Continuous	103.0dB(A) @ 1m	Tone 2	Tone 5
Tone 16	660Hz 150mS on, 150mS off Intermittent	104.0dB(A) @ 1m	Tone 18	Tone 5
Tone 17	1544Hz (100mS)/440Hz (400mS) - NF S 32-001	107.0dB(A) @ 1m	Tone 2	Tone 27
Tone 18	660Hz 1.8sec on, 1.8sec off Intermittent	105.0dB(A) @ 1m	Tone 2	Tone 5
Tone 19	1.4KHz-1.6KHz 1s, 1.6KHz-1.4KHz 0.5s -NFC48-265	117.0dB(A) @ 1m	Tone 2	Tone 5
Tone 20	660Hz Continuous	104.0dB(A) @ 1m	Tone 2	Tone 5
Tone 21	554Hz/440Hz @ 1Hz Alternating	107.0dB(A) @ 1m	Tone 2	Tone 5
Tone 22	544Hz @ 0.875 sec. Intermittent	107.0dB(A) @ 1m	Tone 2	Tone 5
Tone 23	800Hz @ 2Hz Intermittent	103.0dB(A) @ 1m	Tone 6	Tone 5
Tone 24	800/1000Hz @ 50Hz Sweeping	107.0dB(A) @ 1m	Tone 29	Tone 5
Tone 25	2400/2900Hz @ 50Hz Sweeping	109.0dB(A) @ 1m	Tone 29	Tone 5
Tone 26	Bell	117.0dB(A) @ 1m	Tone 2	Tone 1
Tone 27	554Hz Continuous	107.0dB(A) @ 1m	Tone 26	Tone 5
Tone 28	440Hz Continuous	104.0dB(A) @ 1m	Tone 2	Tone 5
Tone 29	800/1000Hz @ 7Hz Sweeping	106.0dB(A) @ 1m	Tone 7	Tone 5
Tone 30	AS2220: 420Hz repeating 0.625 sec on, 0.625 sec off.	104.0dB(A) @ 1m	Tone 32	Tone 5
Tone 31	660/1200Hz @ 1Hz Sweeping	110.5dB(A) @ 1m	Tone 11	Tone 1
Tone 32	AS2220: 500-1200Hz 3.75s on 0.25s off (15 cycles/min)	110.5dB(A) @ 1m	Tone 26	Tone 1

Current consumption:

Version:	Alarm Sounder		LED Beacon	
	Voltage range:	Current:	Voltage range:	Current:
12V dc	+/-25%	195mA	10-50V	760mA
24V dc	+/-25%	265mA	10-50V	400mA
48V dc	+/-25%	130mA	10-50V	210mA
115V ac 50/60Hz	+/-10%	110mA	+/-10%	135mA
230V ac 50/60Hz	+/-10%	56mA	+/-10%	65mA



INSTRUCTION MANUAL (ATEX / IECEx)

BExCS110-L1D

Flameproof Combined Sounder / LED Beacon

1) Introduction

The BExCS110-L1D is a flameproof combined sounder / LED beacon which is certified meet the requirements of the ATEX directive 94/9/EC and the IECEx Scheme. The combined unit produces both loud audio warning signals and visual warning signals that can be used in hazardous areas where potentially flammable atmospheres may be present. Thirty-two different first stage audio alarm sounds can be selected by internal switches, and each one can be externally changed to a second or third stage alarm sound (see *tone table on Page 5*). The sounder produces output levels in the 110dB(A) range. Nine different flash patterns can be selected including a steady ON state and can also be remotely switched to a second and third flash pattern (see *flash pattern table on page 5*). The unit can be used in Zone 1 and Zone 2 areas with gases in groups IIA and IIB and with Temperature Classifications of T1, T2, T3 and T4.

2) Marking

All units have a rating label, which carries the following important information:-

Unit Type No. BExCS110-L1D

Input Voltage: DC Units 12V or 24V or 48V
 AC Units 230V or 115V

Code: Ex d IIB T4 for Ta -50°C to +70°C

Certificate No. KEMA 01ATEX2223X
 IECEx KEM 10.0025X

Epsilon x:
 Equipment Group
 and Category:

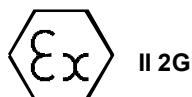

CE Marking:
 Notified Body No.

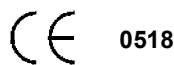

“Warnings” DO NOT OPEN WHEN AN EXPLOSIVE
 GAS ATMOSPHERE IS PRESENT

COVER BOLTS CLASS A4-80

USE HEAT RESISTING CABLES AND
 CABLE GLANDS (Rated 110°C) AT
 AMB. TEMPERATURES OVER 40°C

Year of Construction /
 Serial No. i.e. 10 / 1CS51000001

3) Type Approval Standards

The units have an EC Type examination certificate issued by KEMA and have been approved to the following standards:-

EN60079-0:2006 IEC60079-0:2004 (Ed4) General Requirements
 EN60079-1:2007 IEC60079-1:2007 (Ed6) Flameproof Enclosure 'd'

4) Installation Requirements

The unit must be installed in accordance with the latest issues of the relevant parts of the EN60079 specifications or the equivalent IEC specifications – Selection, Installation and maintenance of electrical apparatus for use in potentially explosive atmospheres (other than mining applications or explosive processing and manufacture):-

EN60079-14:2008 Electrical Installations in Hazardous
 IEC60079-14:2007 (Ed4) Areas (other than mines)

EN60079-10:2003 Classification of Hazardous Areas
 IEC60079-10:2008 (Ed1)

The installation of the unit must also be in accordance with any local codes that may apply and should only be carried out by a competent electrical engineer who has the necessary training.

5) Zones, Gas Group, Category and Temperature Classification

The BExCS110-L1D unit has been certified Ex d IIB T4 for Ta -50°C to +70°C. This means that the units can be installed in locations with the following conditions:-

Area Classification:

Zone 1	Explosive gas air mixture likely to occur in normal operation.
Zone 2	Explosive gas air mixture not likely to occur, and if it does, it will only exist for a short time.

Gas Groupings:

Group IIA	Propane
Group IIB	Ethylene

Equipment Category: 2G

Temperature Classification:

T1	400°C
T2	300°C
T3	200°C
T4	135°C

Ambient Temperature Range:

-50°C to +70°C

6) Location and Mounting

The location of the unit should be made with due regard to the area over which both the sounder and beacon warning signal must be audible and visible. The unit should only be fixed to services that can carry the weight of the unit.

The unit should be securely bolted to a suitable surface using the 7mm diameter boltholes in the stainless steel U shaped mounting bracket (see figure 1). The angle can then be adjusted in the direction such that its warning signals can be both heard and seen. This can be achieved by loosening the two large bracket screws in the side of the unit, which allow adjustment in steps of 18°. On completion of the installation the two large bracket adjustment screws on the side of the unit must be fully tightened to ensure that the unit cannot move in service.

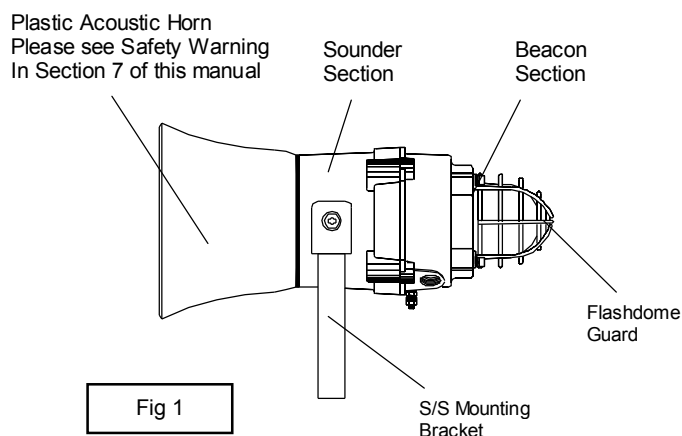

Carefully push the beacon section in place allowing time for the air to be expelled. Only after the beacon section casting is fully in place should the four M6 Stainless Steel A4-80 cover bolts and their spring washer be inserted and tightened down. If the beacon section jams while it is being inserted, carefully remove it and try again. Never use the cover bolts to force the beacon section casting into position.

In case of repair, contact the manufacturer for information on the dimensions of the flameproof joints.

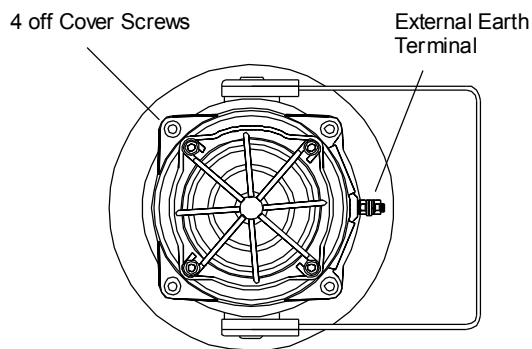

Fig 2

9) Power Supply Selection

It is important that a suitable power supply is used to run the unit. The power supply selected must have the necessary capacity to provide the input current to all of the units connected to the system. The sounder and LED beacon sections can both be wired to the same power supply or to different power supplies.

The following table shows the input current taken by the sounder section and beacon section of the various units:-

Unit Type	Input Voltage	Sounder Current	Max. I/P Volts
BExCS110-L1D	24V DC	265mA	30V
BExCS110-L1D	12V DC	195mA	15V
BExCS110-L1D	48V DC	130mA	50V
BExCS110-L1D	230V AC	56mA	253V
BExCS110-L1D	115V AC	110mA	126V

Unit Type	Input Voltage	LED Beacon Current	Max. I/P Volts
BExCS110-L1D	24V DC	400mA	30V
BExCS110-L1D	12V DC	760mA	15V
BExCS110-L1D	48V DC	130mA	50V
BExCS110-L1D	230V AC	65mA	253V
BExCS110-L1D	115V AC	135mA	126V

The above table also shows the maximum voltages at which the units can be operated.

Sounder Section

The input current to the sounder section will vary according to the voltage input level and the frequency of the tone selected. The current levels shown above are for the 440Hz Continuous tone @ nominal input voltage. The 24V and 48V DC units and the 230V AC, 115V AC units have a switching voltage regulator circuit and therefore the input current level will decrease slightly as the input voltage is increased and

7) Safety Warning (Electrostatic Hazard)

The acoustic horn section is made of ABS Plastic, therefore to avoid a possible ELECTROSTATIC CHARGE the unit must only be cleaned with a damp cloth.

8) Access to the Flameproof Enclosure

In order to connect the electrical supply cables to the unit it is necessary to remove the beacon section to gain access to the flameproof chamber. To achieve this remove the four M6 hexagon socket head screws (see figure 2) and withdraw the beacon section taking extreme care not to damage the flameproof joints in the process.

Note the four **M6 screws are Class A4-80 stainless steel and only screws of this category can be used on these units.** It is therefore important that these screws and their spring washers are kept in a safe place during installation.

On completion of the cable wiring installation the flameproof joints should be inspected to ensure that they are clean and that they have not been damaged during installation. Also check that the earth bonding wire between the two casting sections is secure and the 'O' ring seal is in place. When replacing the beacon section casting, ensure that it is square with the sounder section chamber casting before inserting.

will increase slightly as the input voltage is reduced. The 12V units do not have a voltage regulator and therefore their input current will increase when the input voltage is increased.

LED Beacon Section

The input current to the beacon section will vary according to the voltage input level. The current levels shown above are for nominal input voltages of 12V, 24V and 48V DC the units have a converter circuit and therefore the input current level will decrease slightly as the input voltage is increased and will increase slightly as the input voltage is reduced.

10) Cable Selection

When selecting the cable size consideration must be given to the input current that each unit draws (see table above), the number of units on the line and the length of the cable runs. The cable size selected must have the necessary capacity to provide the input current to all of the units connected to the line.

SAFETY WARNING: If the unit is used at high ambient temperatures, i.e. over +40°C, then the cable entry temperature may exceed +70°C and therefore suitable heat resisting cables must be used, with a rated service temperature of at least 110°C.

11) Earthing

Both AC and DC units must be connected to a good quality earth. The units are provided with internal and external earthing terminals, which are both, located on the beacon section of the unit (see figures 2 and 3).

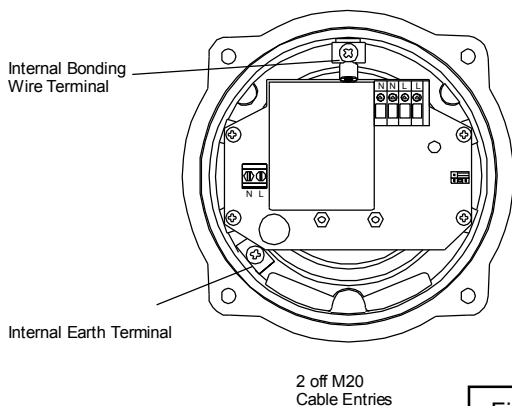

Figure 3

When using the external earth terminal a cable crimp lug must be used. The cable lug should be located between the two M5 stainless steel flat washers. The M5 stainless steel spring washer must be fixed between the outer flat washer and the M5 stainless steel nut to ensure that the cable lug is secured against loosening and twisting.

The internal earth bonding wire ensures that a good quality earth is maintained between the sounder section casting and the beacon section casting.

12) Cable Glands

The BExCS110-L1D unit has dual cable gland entries which have an M20 x1.5 entry thread as standard. Only cable

glands approved for Ex 'd' applications can be used, which must be suitable for the type of cable being used and also meet the requirements of the Ex 'd' flameproof installation standard EN60079-14:2008 / IEC60079-14:2007 .

SAFETY WARNING: If the unit is used at high ambient temperatures, i.e. over +40°C, then the cable entry temperature may exceed +70°C and therefore suitable heat resisting cable glands must be used, with a rated service temperature of at least 110°C.

If a high IP (Ingress Protection) rating is required then a suitable sealing washer must be fitted under the cable gland.

When only one cable entry is used the other one must be closed with an Ex 'd' flameproof blanking plug, which must be suitably approved for the installation requirements.

13) Cable Connections

The combined sounder LED beacon unit BExCS110-L1D has separate printed circuit boards in the sounder and LED beacon sections. The terminals for the sounder are on the printed circuit board in the sounder section and the terminals for the beacon are on the printed circuit board in the beacon section (see figures 4&5 and 6&7). See section 8 of this manual for access to the enclosure and the wiring diagrams at the end of this manual.

The sounder and LED beacon sections can be wired to the same input supply so that they operate simultaneously or they can be wired to separate input supplies so they can be operated independently (see diagrams on page 6 of this manual). If the sounder and beacon sections are connected to the same input supply, the incoming cables should be connected to the input terminals on the LED beacon board and the two connecting wires, that are supplied with the unit, should be used to link the supply from the interconnecting terminals on the beacon board down to the supply terminals on the sounder board.

SOUNDER SECTION CONECTIONS

On the AC units a two-way terminal block is provided for the live and neutral mains supply wires and a three way terminal block is provided for linking the second and third stages, (see figure 7). On the DC units a four way terminal block is provided for +ve and -ve supply input and second and third stage modes of operation, (see figure 6).

A single wire with a cross sectional area of up to 4mm² can be connected to each terminal way or if an input and output wire is required two 2.5mm² wires can be connected to each terminal way. When connecting wires to the terminals great care should be taken to dress the wire so that when the beacon section is inserted into the chamber the wires do not exert excess pressure on the terminal blocks. This is particularly important when using cables with large cross sectional areas such as 2.5mm² and above. If the sounder is wired to the same power supply as the beacon always use the flexible interconnecting wires provided.

LED BEACON SECTION CONNECTIONS

The cable supply connections are made into the terminal blocks on the electronic pcb assembly located in the flameproof LED beacon section enclosure, see section 8 of this manual for access to the flameproof enclosure. The AC unit has two live terminals and two neutral terminals for the input and output supply wiring and the DC unit has two +ve

terminals and two -ve terminals for the input and output supply wiring. Both units have S2 and S3 terminals to remotely change the flash pattern, see section 16 of this manual.

Wires having a cross sectional area of up to 4mm² can be connected to each terminal way. When connecting wires to the terminals great care should be taken to dress the wires so that wires do not exert excess pressure on the terminal blocks. This is particularly important when using cables with large cross sectional areas such as 2.5mm² and above.

BExCS110-L1D AC LED Beacon Section

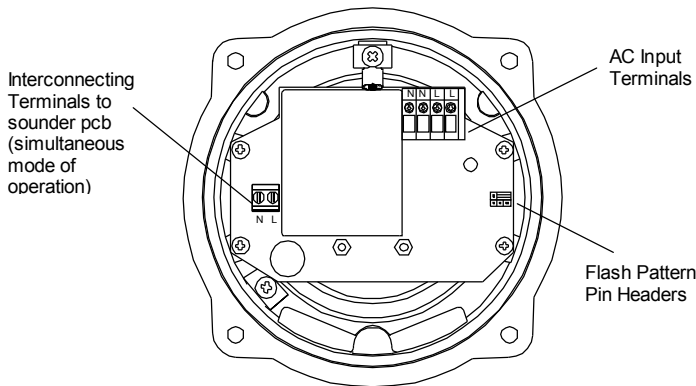

Figure 4

BExCS110-L1D DC Beacon Section

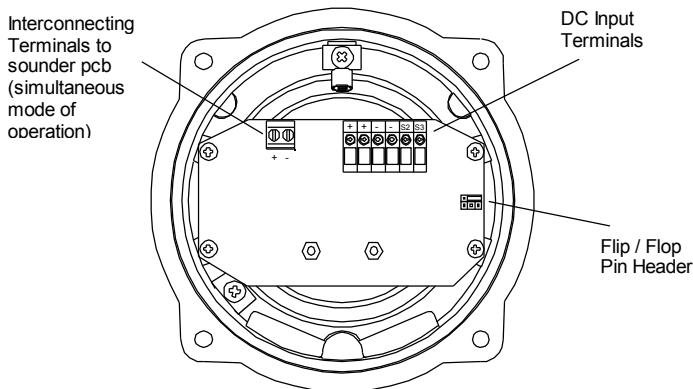

Figure 5

14) Tone Selection and 2nd and 3rd Stage Alarms

The BExCS110-L1D sounder section has 32 different tones that can be selected for the first stage alarm. The sounders can then be switched to sound second and third stage alarm tones. The tones are selected by operation of a DIP switch on the sounder pcb for both DC and AC units. The tone table on page five shows the switch positions for the 32 tones and which tones are available for the second and third stages. To operate the sounder on stage one simply connect the supply voltage to the normal supply terminals (+ve and -ve for DC units, L and N for AC units).

The operation of the second and third stages is different for DC and AC units.

DC Units Second and Third Stage Tone Selection

The BExCS110-L1D DC sounder section has the facility to use either +ve or -ve switching to change the tone to the second and third stages. For -ve switching connect the two headers on the pcb to the left-hand (marked -ve) and centre pins. For +ve switching connect the headers to the right hand (marked +ve) and the centre pins. To change to the second stage tone, connect either a -ve or +ve supply line to terminal S2, depending on which switching mode is being used while maintaining the dc supply to the +ve and -ve terminals. Similarly for the third stage tone, connect a -ve or +ve supply line to terminal S3. The supply to the S3 terminal will automatically override a supply to the S2 terminal.

AC Units Second and Third Stage Tone Selection

To select the second and third stage tones on the BExCS110-L1D AC sounder section, the Common (C) terminal on the three way terminal block on the pcb is connected to the S2 terminal for the second stage tone and the S3 terminal for the third stage tone.

BExCS110-L1D DC Sounder Section

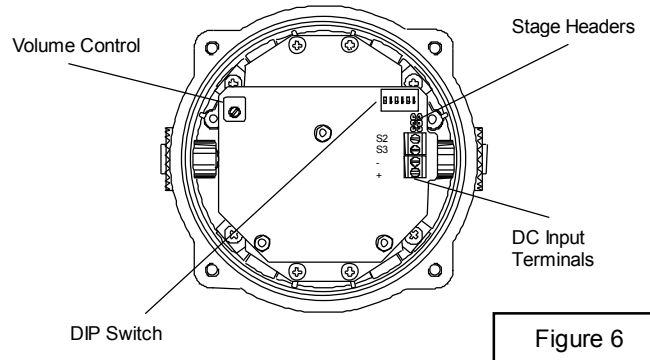

Figure 6

BExCS110-L1D AC Sounder Section

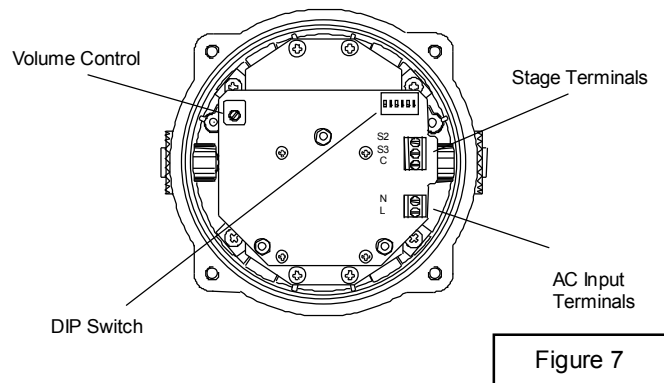
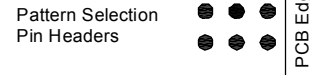

Figure 7

15) Volume Control

The BExCS110-L1D sounder section, with the exception of 12V DC units, has a volume control to adjust the output level. To set the required output level, adjust the potentiometer on

the pcb. For maximum output level the potentiometer should be set to the fully clockwise position.



16) Flash Pattern Selection and 2nd & 3rd Stages

The BExCS110-L1D LED beacons have 9 different flash patterns including one ON state that can be selected for the first stage. They can then be remotely switched to second and third stage flash patterns. The flash patterns are selected by pin headers on the pcb for both DC and AC units. The table on page five shows the pin header positions for the nine flash patterns and which patterns are available for the second and third stages. To operate the led beacon on stage one simply connect the supply voltage to the normal supply terminals (+ve and -ve for DC units, L and N for AC units).

The operation of the second and third stages is different for DC and AC units.

DC Units Second and Third Stage Selection

To change to the second stage flash pattern, simply connect a -ve supply line to terminal S2, while maintaining the dc supply to the +ve and -ve terminals. Similarly for the third stage flash pattern, connect a -ve supply line to terminal S3. The supply line to the S3 terminal will automatically override a supply to the S2 terminal.

AC Units Second and Third Stage Selection

To select the second and third stage flash patterns on the BExCS110-L1D AC beacons the Common (C) terminal on the three way terminal block on the pcb is connected to the S2 terminal for the second stage tone and the S3 terminal for the third stage tone.

Flash Pattern Table

Stage 1 Pattern	LED Flash Pattern	Stage 2 Pattern	Stage 3 Pattern
1	ON	9	8
2	Rotating 3 LED on Fast	7	1
3	Rotating 6 LED on Fast	8	1
4	Rotating 3 LED on Slow	9	1
5	Rotating 6 LED on Slow	6	1
6	Double strike strobe 1 Hz	9	1
7	Single strike strobe 2 Hz	3	1
8	Double strike strobe 2 Hz	3	1
9	Alternate side flash 1:1 2 Hz	3	1

PIN HEADER POSITIONS

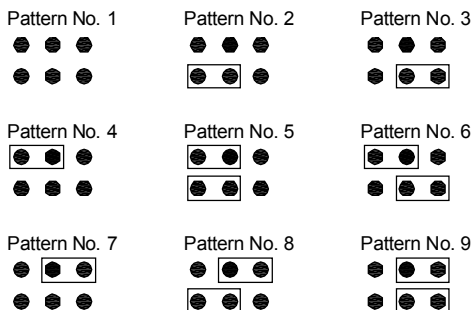

17) Line Monitoring (DC Units)

On BExCS110-L1D DC units, dc reverse line monitoring can be used if required. All DC units have a blocking diode fitted in their supply input lines on both the sounder section and the LED beacon section. An end of line monitoring diode or an end of line monitoring resistor can be connected across the +ve and -ve terminals. If an end of line resistor is used it must have a minimum resistance value of 3k3 ohms and a minimum wattage of 0.5 watts or a minimum resistance value of 500 ohms and a min. wattage of 2 watts. If the sounder and beacon sections are wired to separate power supplies, then an end of line monitoring component can be used in each section.

STONE SELECTION TABLE

Tone Selection		DIP Switch Settings					Stage Selection	
Stage 1	Frequency Description	1	2	3	4	5	Stage 2	Stage 3
1	Continuous 1000Hz <i>Toxic gas alarm</i>	0	0	0	0	0	Tone 31	Tone 11
2	Alternating 800/1000Hz at 0.25s intervals	1	0	0	0	0	Tone 17	Tone 5
3	Slow Whoop 500/1200Hz at 0.3Hz with 0.5s gap repeated	0	1	0	0	0	Tone 2	Tone 5
4	Sweeping 800/1000 at 1Hz	1	1	0	0	0	Tone 6	Tone 5
5	Continuous at 2400Hz	0	0	1	0	0	Tone 3	Tone 27
6	Sweeping 2400/2900Hz at 7Hz	1	0	1	0	0	Tone 7	Tone 5
7	Sweeping 2400/2900Hz at 1Hz	0	1	1	0	0	Tone 10	Tone 5
8	Siren 500/1200/500Hz at 0.3Hz	1	1	1	0	0	Tone 2	Tone 5
9	Sawtooth 1200/500Hz at 1Hz	0	0	0	1	0	Tone 15	Tone 2
10	Alternating 2400/2900Hz at 2Hz	1	0	0	1	0	Tone 7	Tone 5
11	Intermittent 1000Hz at 0.5Hz <i>General alarm</i>	0	1	0	1	0	Tone 31	Tone 1
12	Alternating 800/1000Hz at 0.875Hz	1	1	0	1	0	Tone 4	Tone 5
13	Intermittent 2400Hz at 1Hz	0	0	1	1	0	Tone 15	Tone 5
14	Intermittent 800Hz 0.25s on 1s off	1	0	1	1	0	Tone 4	Tone 5
15	Continuous at 800Hz	0	1	1	1	0	Tone 2	Tone 5
16	Intermittent 660Hz 150mS on, 150mS off	1	1	1	1	0	Tone 18	Tone 5
17	Alternating 544Hz (100mS)/440Hz(400mS)	0	0	0	0	1	Tone 2	Tone 27
18	Intermittent 660Hz 1.8s on, 1.8s off	1	0	0	0	1	Tone 2	Tone 5
19	1400Hz to 1600Hz sweep up over 1s - 1600Hz to 1400Hz sweep down over 0.5s	0	1	0	0	1	Tone 2	Tone 5
20	Continuous 660Hz	1	1	0	0	1	Tone 2	Tone 5
21	Alternating 554/440Hz at 1Hz	0	0	1	0	1	Tone 2	Tone 5
22	Intermittent 554Hz at 0.875Hz	1	0	1	0	1	Tone 2	Tone 5
23	800Hz pulsing at 2Hz	0	1	1	0	1	Tone 6	Tone 5
24	Sweeping 800/1000Hz at 50Hz	1	1	1	0	1	Tone 29	Tone 5
25	Sweeping 2400/2900Hz at 50Hz	0	0	0	1	1	Tone 29	Tone 5
26	Simulated bell sound	1	0	0	1	1	Tone 2	Tone 1
27	Continuous 554Hz	0	1	0	1	1	Tone 26	Tone 5
28	Continuous 440Hz	1	1	0	1	1	Tone 2	Tone 5
29	Sweeping 800/1000Hz at 7Hz	0	0	1	1	1	Tone 7	Tone 5
30	420Hz repeating 0.625s on, 0.625s off <i>Australian alert signal</i>	1	0	1	1	1	Tone 32	Tone 5
31	1200/500Hz at 1Hz <i>Prepare to abandon platform</i>	0	1	1	1	1	Tone 11	Tone 1
32	Sweeping 500/1200Hz 3.75s on, 0.25s off 15Hz	1	1	1	1	1	Tone 26	Tone 1

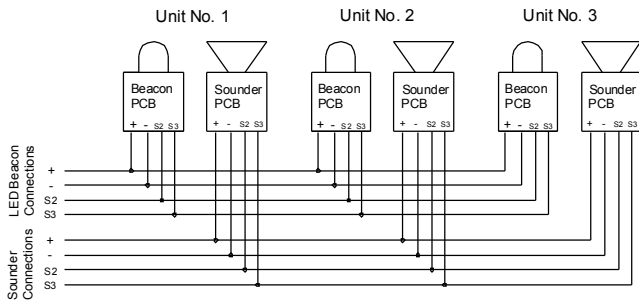

BExCS110-L1D DC Combined Sounder Unit
LED Beacon and Sounder Wired for Independent Operation

NOTE
 Either the +ve or the -ve wire may be made common to both the sounder and the beacon to reduce the number of cores in the cable.

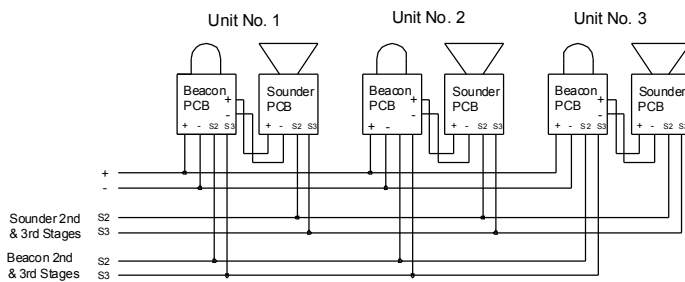

BExCS110-L1D DC Combined Sounder Unit
LED Beacon and Sounder Wired for Simultaneous Operation

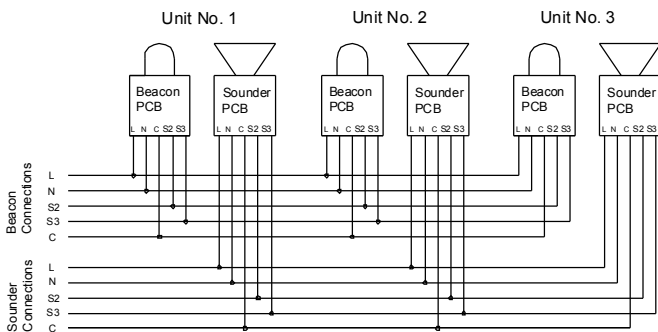

BExCS110-L1D AC Combined Sounder Unit
LED Beacon and Sounder Wired for Independent Operation

NOTE
 Either the L or the N wire may be made common to both the sounder and the beacon to reduce the number of cores in the cable.

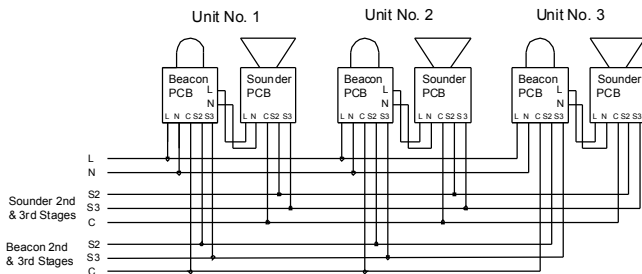

BExCS110-L1D AC Combined Sounder Unit
LED Beacon and Sounder Wired for Simultaneous Operation